



**VOGE**

Far & Beyond Quality

# MOTORCYCLE OPERATION MANUAL SR1ADV



# Welcome to VOGÉ

We say thanks and express our congratulations to your correct choosing on VOGÉ.

You need to know your motorcycle as well as yourself, to safely drive under various conditions. Please carefully read this book before your first driving, which includes important information and suggestion about driving and its equipment, also the maintenance and pre-cautions. In case there are some questions about this motorcycle, the VOGÉ dealers are very glad to suggest and help you. We hope you enjoy your every minute on driving.

Please purchase the helmet meets standard GB811 when you buying our motorcycle at VOGÉ dealer as possible, and wear it when you were driving.

## Important information about this book

This book includes the important information, issues need pay attention to, warning and cautions about the motorcycle, so please always keep it on the motorcycle even lend or sell to others, this is very important. The pictures or details in this book may be different with the actual motorcycle, but their description and principle are the same. This book is a part of the motorcycle, keep it always on the vehicle even sell or lend. VOGÉ improves its products all the time to make sure its high quality and safety performance, so the information in this book may not be complete same with your actual motorcycle, in this case, the VOGÉ dealers are glad to provide your correct suggestions.

This user manual meets the standards: GB/T 19678.1、GB/T 9969、GB/T 40494

All rights of final interpretation belong to Loncin Motor co.ltd.

# Content list

|   |    |   |    |
|---|----|---|----|
| <b>I.Issues need pay attention to</b> .....       | 1  | ABS system .....                                | 25 |
| <b>II.Safe driving</b> .....                      | 2  | Driving recorder(Optional) .....                | 26 |
| Loading, accessories and refit.....               | 2  | TCS traction control system .....               | 28 |
| Checking before driving.....                      | 3  | Main stand system .....                         | 29 |
| Issues need pay attention to during driving ..... | 4  | Engine starting .....                           | 30 |
| Driving on road .....                             | 5  | Fuel filling-up.....                            | 31 |
| Braking and parking .....                         | 6  | <b>VI.Malfunctions</b> .....                    | 32 |
| <b>III.Main parameters</b> .....                  | 7  | Too hot the coolant.....                        | 32 |
| <b>IV.Structure of motorcycle</b> .....           | 8  | Insufficient coolant .....                      | 32 |
| Identification for motorcycle.....                | 8  | Engine starting failure.....                    | 33 |
| Head part .....                                   | 9  | Difficult engine starting.....                  | 33 |
| Left side.....                                    | 10 | Weak engine power output .....                  | 33 |
| Right side.....                                   | 11 | Malfunction' s inspection and maintenance ..... | 33 |
| Lower side of seat .....                          | 12 | <b>VII.Grinding-in</b> .....                    | 34 |
| <b>V. Operation</b> .....                         | 14 | Grinding-in for new motorcycle .....            | 34 |
| Ignition switch.....                              | 14 | Grinding-in for engine .....                    | 34 |
| Instrument and its indicating light.....          | 16 | Grinding-in for tire .....                      | 35 |
| LED+Negative display .....                        | 20 | Grinding-in for brake system.....               | 35 |
| Steering switch set.....                          | 22 | <b>VIII.Adjustment</b> .....                    | 36 |
| USB power socket .....                            | 24 |   |    |

|   |           |   |           |
|---|-----------|---|-----------|
| Adjustment for back-view mirror .....               | 36        | Replacement for secondary fuel filter .....                   | 60        |
| Adjustment for throttle grip.....                   | 37        | The replacement for light signal .....                        | 61        |
| Adjustment for headlight dimmer .....               | 38        | Maintenance plan.....   | 62        |
| <b>IX. Inspection, repair and maintenance .....</b> | <b>39</b> | <b>X. Maintenance for the motorcycle in long parking.....</b> | <b>65</b> |
| Fuel.....   | 39        | Storage for motorcycle.....                                   | 65        |
| The fuel evaporation.....                           | 40        | Protection for motorcycle.....                                | 66        |
| Three-way catalyst.....                             | 41        | The cleaning up for motorcycle.....                           | 66        |
| Tool box.....                                       | 42        | <b>XI. Electrical diagram .....</b>                           | <b>67</b> |
| Moving parts and their maintenance.....             | 42        |   |           |
| Battery .....                                       | 42        |   |           |
| External power supply .....                         | 44        |   |           |
| Maintenance for air filter.....                     | 45        |   |           |
| Oil in engine.....                                  | 46        |   |           |
| Replacement for oil filter' s element .....         | 50        |   |           |
| Coolant .....                                       | 51        |   |           |
| Brake liquid .....                                  | 54        |   |           |
| Tire .....  | 55        |   |           |
| Fuse chip .....                                     | 57        |   |           |
| The brake pads.....                                 | 59        |   |           |

## I.Issues need pay attention to

This user manual has the warning marks as below, when you saw it, please follow these driving and maintenance procedure.

 **Danger** This mark indicates it may lead to bad injury even death.

 **Warning** This mark indicates it may lead to damage on motorcycle.

 **Caution** This mark means more effective and convenient point for driving.

### **Danger**

This book fits for the driver with license only, please correctly and cautiously drive and pay attention to:

Refit at will is not allowed;

Please follow the local laws and regulations;

Any refit on this motorcycle may be bad for noise, emission and performance.

Because we keep improvements on motorcycle, so the actual motorcycle may not be complete same with !this book, please set the actual motorcycle as standard while without further information.

## II.Safe driving

### Loading, accessories and refit

You can get the origin VOGÉ and authorized parts, accessories and other products from our official dealers, meanwhile, the specialized workers will introduce you how to use and assemble.

Please always adopt origin VOGÉ parts or our authorized ones. The parts nor from VOGÉ factory, incorrect accessories or loading are bad for motorcycle performance even break laws, please take responsibility for your safety and that of others.

#### Caution

- The parts this model equipped have passed the test for safety, practicability, and matching performance, and we take responsibility for them, otherwise, we have no responsibility for the parts not from us or without our authorization. So we strongly suggest you adopt the parts and accessories from VOGÉ factory only.
- All your replacement for parts must obey local laws. Make sure your motorcycle won't break any laws and regulations

#### Danger

- Incorrect loading, refit, accessories and maintenance are all hidden risk, before driving, make sure there is not any overloading and obey the stipulations above.
- Refit the electrical or controlling parts at will may damage your motorcycle even lead to accident.

Change the curb weight of motorcycle may be bad for its power performance, so please surely adopt the cargo weight, passenger numbers and accessories from our suggestion only.

## Checking before driving

Before driving, make the inspections as below to reduce accident or damage:

### Steering system

- Flexible turning without jamming
- No runout or flexibility on steering stem

### ·Throttle

- Correct throttle cable clearance

- smooth operation
- without jamming

### ·Brake assy

- The operation is normal.
- Correct brake liquid level in oil cup
- Clear pressing point in braking
- No water and oil residual on

### ·Tire

- The air pressure in tire is correct.
- The depth for tire read is within limit.
- There is not crack or damage on surface of tire

### ·Oil in engine

- Correct oil level
- Cooling system
- Correct coolant level
- No coolant leakage

### ·light

- Headlight/ Front position light, tail light/brake light, turning signal light, frustration plate light and instrument lights
- brake plate and friction pad
- The lights can normally work

### ·Indicating light

- Control through switch assy, the turning signal, high beam indicating light could normally work.
- The oil pressure alarm light, engine malfunction light, water temperature

light and fuel alarm light are not on or flashing when engine started.

### ·Horn

- Fine performance

### ·Side stand

- Normally pick up and lay down
- Normal interlock with ignition switch

### ·Back mirror

### ·Shock absorber

- press down and normally return
- Sit on the motorcycle to keep it upright, and could see a material with width of 4m and 10m to the tail of motorcycle from back view mirror.
- In case it could not be seen clearly, please adjust the angle of back-view mirror.

## Issues need pay attention to during driving

1. Any driver must know well about the motorcycle, the incorrect sitting position or off set during driving may be bad for operation or control of motorcycle; When driving, the passenger need. stably sit on his seat without influence driver. Passenger is an animal is not allowed.
  2. Keep the luggage low to decrease the influence on focus, also the weight of luggage needs evenly spread on both sides, please avoid the luggage extend too long.
  3. The luggage must fix on the motorcycle firmly, make sure it could not move before driving, in case it is unstable in driving, please check its fixing once again, and adjust if it is necessary.
  4. Too heavy or big the luggage is not allowed, the overloading must be bad for driving and performance.
  5. The accessories or luggage may decrease motorcycle performance shall not be loaded, make sure all what you do may not be bad for lighting system, ground clearance, brake performance, side angle, operation, compression distance of tire, working travel for front shock absorber or other performance related to driving.
  6. More weight on handle bar or front fork may be and for turning, and lead to unsafe driving.
  7. Fairing cover, wind shield glass, backrest or other parts with big size may have influence on stability or operation during driving, they increased not only the weight, but also the size, which lower down the power. In case their design lack of test, they may lead to unsafe driving.
  8. Refit to tricycle with side car is not allowed, drawing for other vehicles is also not allowed, and we take no responsibility for refit without authorization.
- The maximum loading: 168kg, including driver, luggage, and accessories.

## Driving on road

- Get on the motorcycle from left side and ride on
  - Pick up the side stand
  - Get the motorcycle upright to the ground, get the handle bar face front, keep its wheel face forward.
  - Tightly hold the brake lever.
  - Slowly turn the throttle grip to accelerate, while slowly releasing the brake lever, the motorcycle slowly start.
  - Wear helmet, gloves, driving boots, protective wear and pans before driving even only for a short driving.
  - In case you drive fast, please pay attention to the factors below which bad for your driving..
- Loose cloths
  - Overload or imbalance load may be bad for your driving and controlling.
  - Don't drive after drink wines, drugs even medicines, even a few alcohol or medicine is bad for your sense and reflection.

### **Caution**

This model equipped the kill switch on side stand, lay down the side stand, the engine stopped immediately.

### **Danger**

Before starting, please pick up the side stand to top position, otherwise, when you turning left, the side stand may touch the ground and lead to accident.

## Braking and parking

- Please decelerate first when braking to reduce the speed and use the front and rear brake at same time.
- When braking, your body get front and press down the front shock absorber, so there is more weight suddenly focus on the front wheel, so the front brake is more reliable, so the front brake is more powerful than the rear one and more easily get motorcycle stop.
- When you are driving on maintain way, use the rear brake only is dangerous, under some limit conditions, the brake may overheat and damage, please use the front, rear brake sand engine coordinately to decelerate.
- Driving in water and rain, the brake plate may get wet and reduce its braking performance, be careful under this situation. Under this case, we suggest you dry it up and then continue the operation.

### **Warning**

- After a long driving, when parking, because the engine is very hot at this moment, so keep it far away from kids to avoid hurt.
- Don't park the motorcycle on soft ground to avoid rollover even damage the motorcycle, in case parking on a gentle slope, let its head face to uphill to avoid the turning of side stand and rollover.
- Parking or running on combustibile materials such as dry grass is not allowed, because the three-way catalyzer is working under very high temperature which is very easy to light up the combustibile materials.

### III. Main parameters

| Motorcycle parameters        |  |                                   |  |
|------------------------------|--|-----------------------------------|--|
| LxWxH                        | 1970mmx770mmx1300mm  | Rear brake type                   | Single plate, single pistons, floating caliper, and fixed plate/Diameter of 220mm                  |
| Wheelbase                    | 1330mm   | ABS                               | Double passage prevent locking-up  |
| Seat height                  | 810mm  | Engine parameters                 |  |
| Ground clearance             | 140mm  | Engine type                       | Singleycylinder/4 strokes/Water cooling/SOHC/Double valves   |
| Curb weight                  | 141kg  | Bore x Stroke                     | 52.4mm x 57.9mm  |
| Max. loading                 | 168kg  | Displacement                      | 124.9ml  |
| Max. Weight                  | 309kg  | Compression ratio                 | 11:1   |
| Front wheel loading          | 60kg   | Clearance of air inlet valve      | (0.06 - 0.08)mm  |
| Rear wheel loading           | 81kg   | Clearance of air exhaust valve    | (0.14 - 0.16)mm  |
| Max. speed                   | 97km/h   | Clearance of spark plug           | 0.6mm-0.8mm  |
| Gradeability                 | ≥ 20%  | Specification of spark plug       | TORCH B8RTC  |
| Braking deceleration         | Follow GB20073-2018  | Maxnetpower output/Rotation speed | 8.5kW/8500rpm  |
| Fuel consumption             | ≤2.7L/100km (Under WMTC working status)  | Max. torque/Rotation speed        | 11N.m/6500rpm  |
| Fuel tank capacity           | 9L   | Idling speed                      | (1700 ±150)r/min   |
| Coolant capacity             | 0.46L  | Gearbox type                      | CVT stepless speed change  |
| Suspension rack/Brake system |  | Clutch type                       | Dry clutch   |
| Front shock absorber type    | Shock absorber/Fork tube φ31mm with stroke of 115mm                                | Oil capacity                      | 0.9L for crankcase of 10W/40- SL or above<br>0.2L for gear box of gear oil of 80W/90-GL-4 or above |
| Rear shock absorber type     | Straight pushing shock absorber/Stroke of 116mm                                    | Fuel supply                       | EFI system   |
| Front wheel hub size         | 2.5 x 14   | Power transmission system         |  |
| Rear wheel hub size          | 3.5 x 13   | Total transmission ratio          | 7.984~24.839   |
| Front tire size              | 110/80-14  | Primary CVT                       | 0.810~2.520  |
| Rear tire size               | 130/70-13  | End transmission ratio            | 9.857  |
| Front brake type             | Single plate, double pistons, floating caliper, and fixed plate /Diameter of 240mm |                                   |  |

## IV. structure of motorcycle

### Identification for motorcycle

The Vehicle Identification Number (VIN) and name plate Engine type number and Delivery number

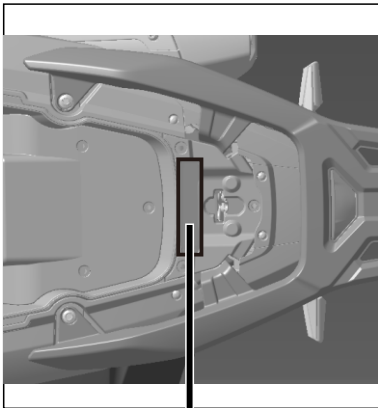

Vehicle Identification number

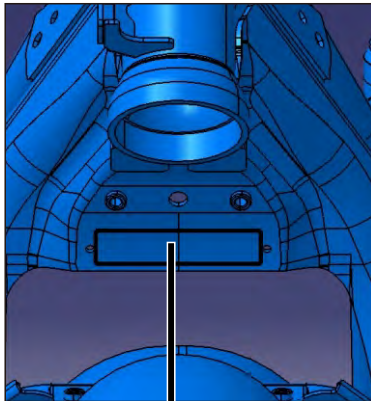

Products number

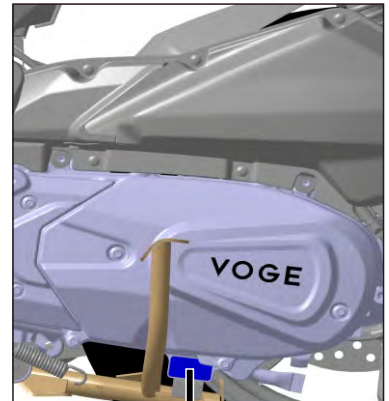

Engine type and Delivery number

## Head part

1. Left back-view mirror
2. Left switch assy
3. Rear brake oil cup
4. Instrument
5. Ignition switch
6. Front brake oil cup
7. Right switch assy
8. Right back-view mirror
9. Front brake lever
10. Greaser
11. **Accelerator base**
12. Fuel tank cap
13. Left grip
14. Rear brake lever

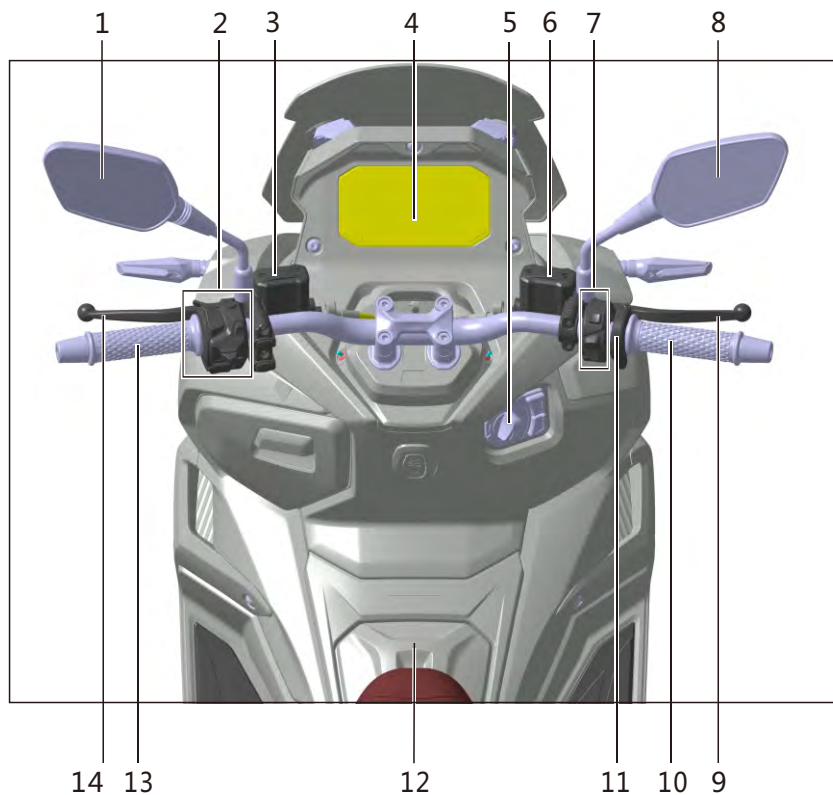

## Left side

- 1.Secondary fuel filter
- 2.Driver seat
- 3.Passenger seat
- 4.Taillight
- 5.Rear registration plate light
- 6.Rear turn signal
- 7.Rear luggage rack
- 8.Main stand
- 9.Left pillion step body
- 10.Left footrest body
- 11.Side stand
- 12.Fuel tank
- 13.Left reflector
- 14.Front lower disc brake pump
- 15.Ring gear for ABS
- 16.Headlight

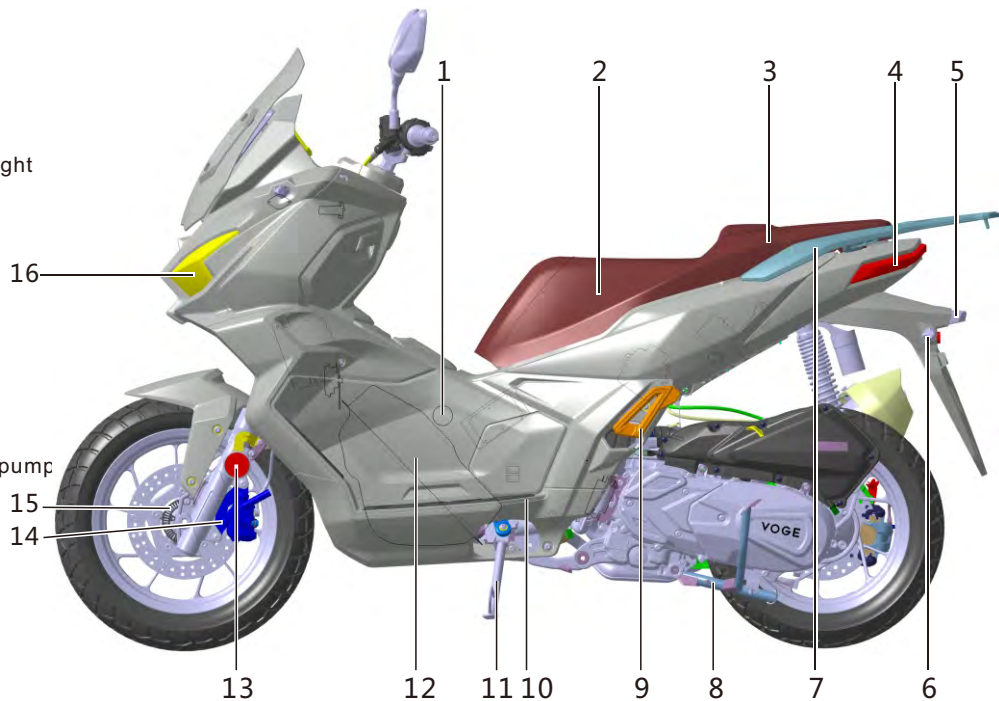

## Right side

- 1.Front turning signal light
- 2.Front disc brake plate
- 3.Right reflector
- 4.Right footrest body
- 5.Water filling up port of heat radiator
- 6.Oil filling up port and oil gauge
- 7.Muffler
- 8.Ring gear of ABS
- 9.Rear disc brake plate
- 10.Rear lower disc brake pump
- 11.Rear luggage rack
- 12.Right pillion step body

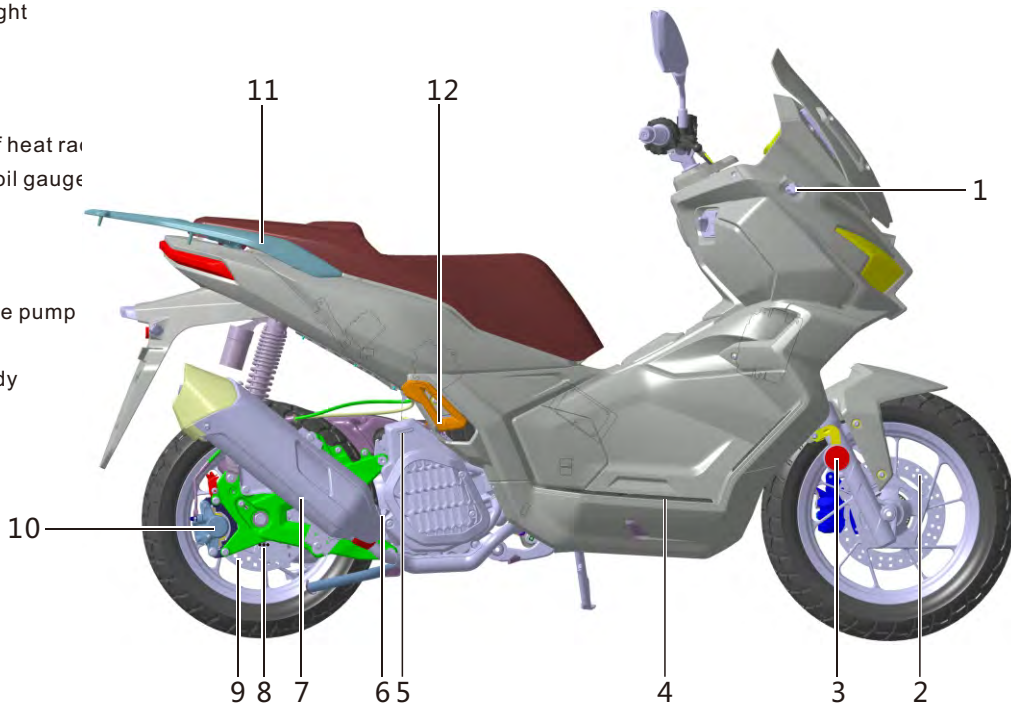

## Lower side of seat

- 1.Main relay
- 2.Driving recorder
- 3.Antenna
- 4.ECU
- 5.Battery
- 6.Camera
- 7.Controller
- 8.Oil pump relay
- 9.Oxygen sensor
- 10.Controller for BCM
- 11.Tool box
- 12.Diagnosis socket for OBD
- 13.Rear reflector

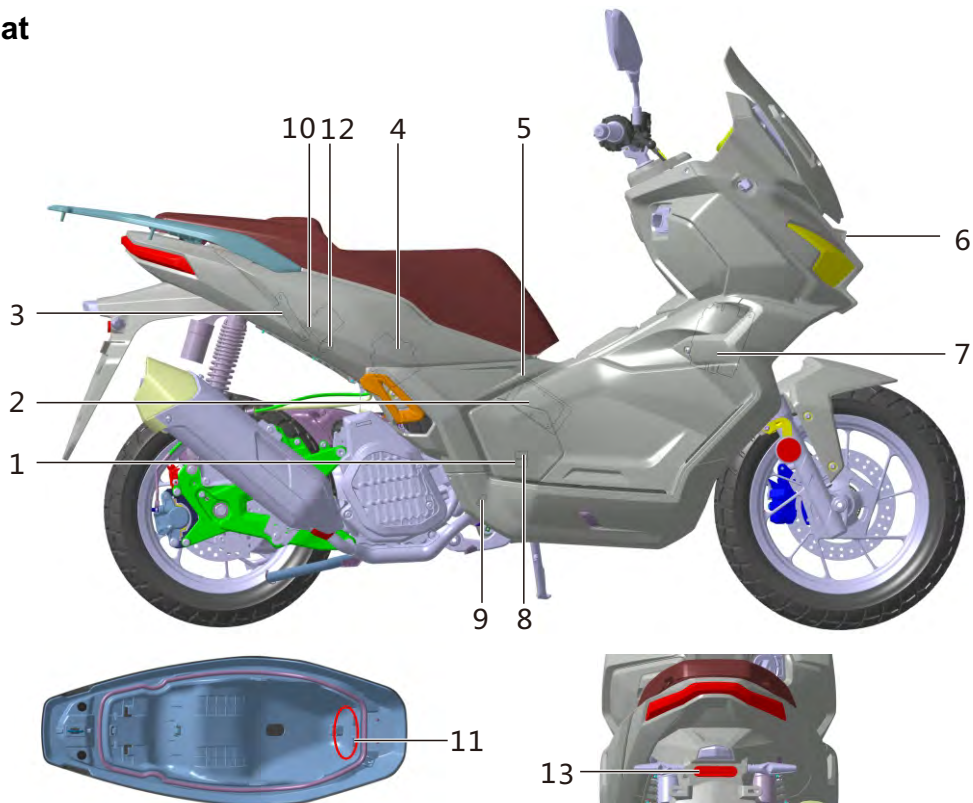

The simplified diagram of 4 fuses is show as below (The power supply of this model divides to 6 branches, in which each gets power from positive terminal of battery, and each branch has its own fuse who are mutually independent without influence)

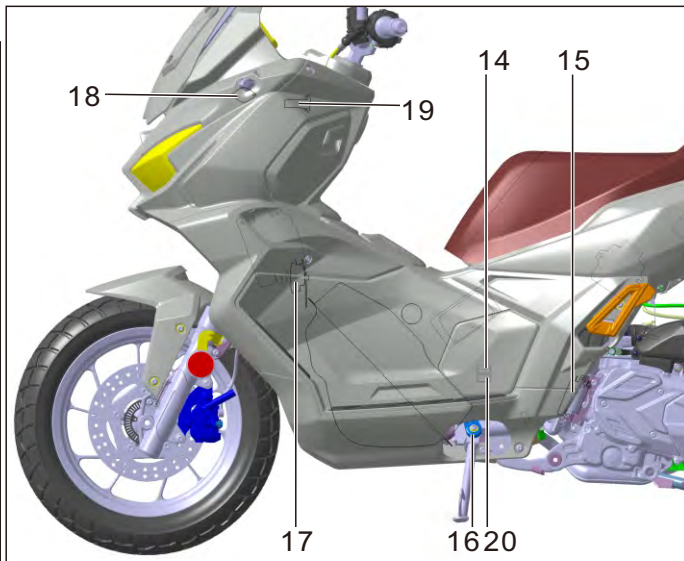
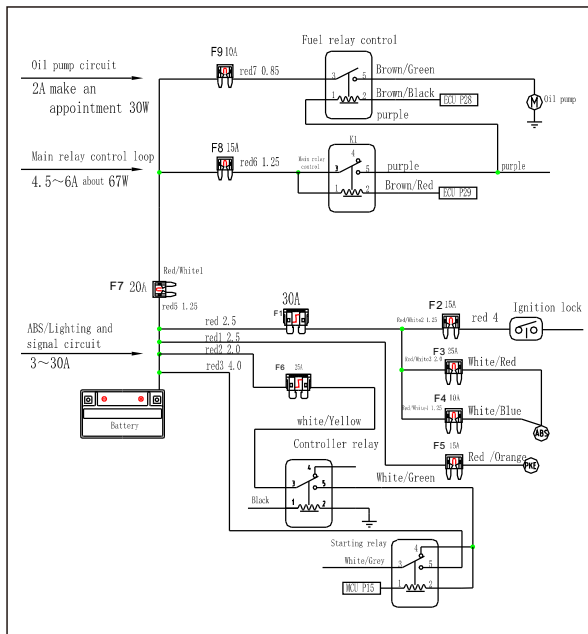

- 14 .Controller relay
- 15 .Ignition coil
- 16 .Kill switch on side stand
- 17 .Horn
- 18 .Alarm of horn
- 19 .USB power socket
- 20 .Starting relay

## V.Operation

### Ignition switch

The ignition switch on this model is at the right side of panel of front luggage case, the ignition switch and steering lock are in one piece.

There are 2 pieces of key for this model, There is a mechanical key included in each remote key, please keep them in place.

The ignition, steering, seat and fuel tank's lock share a same remote-control key.

The mechanical key can open the seat lock, whose hole is at the bottom of seat.

Press the ignition switch, the outer light belt of ignition switch gets on, then turn the ignition switch clockwise to position "  ", the motorcycle gets power on, meanwhile the instrument begins its initialization.

Pick up the side stand, tightly hold the brake lever (The front one only or both the front and rear together), then press the starting button on the right switch assy., the engine normally starts.

Turn the ignition switch to position "  ", the seat lock and fuel tank cap could be opened, then press the key " FUEL " to open the fuel tank switch; Press key " SEAT " to open the seat lock.

Turn the ignition switch to "  ", the motorcycle got power off, while the outer light ring of ignition switch is keeping on, after waited for 4 seconds, in case the remote key is within the range of 1.2m for antenna, and it is the first time the controller scan the remote key, the light ring keeps on for 9 seconds, then the light belt gets off, at the same moment, the buzzer shortly ring, then the motorcycle gets power off and get into automatic anti-theft condition; In case it is the second time scan the remote key, the light ring keeps on for 14 seconds then gets off, at the same time the buzzer shortly ring, then the motorcycle gets power off and get into automatic anti-theft condition; In case it is the third time scan the remote key, the light ring keeps on for 19 seconds (The light ring at most keeps on for 19 seconds, then gets off, at the same time, the

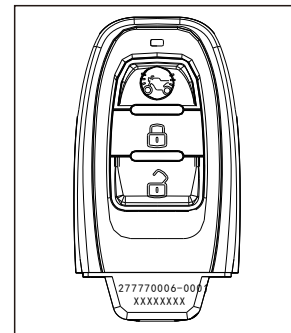
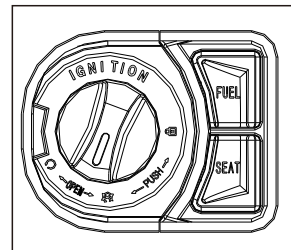

buzzer shortly ring, then the motorcycle gets power off and get into automatic anti-theft condition; In case the remote key is out of range of 1.2m, the light ring keeps on for 4 seconds, at the same time, the buzzer shortly ring, then the motorcycle gets power off and get into automatic anti-theft condition.

Press the remote key "  ", left and right turning signal light, they get on while buzzer long ringing, the working condition of anti-theft gets released.

Press the remote key "  ", start the function of Remote motorcycle search (Without shelter within 30m), the left and right turning signal gets on for 3 times while buzzer shortly ringing for 3 times.

### **Danger**

Please don't turn the ignition key to "  " during driving, otherwise the motorcycle may get out of control.

### **Caution**

Even within the range of 1.2m to antenna, put the remote key to some place may also lead to the abnormal communication between the key and motorcycle, which makes failure of motorcycle power on or starting engine. These places are but not only left front luggage case, position near steering stem, front of instrument, and rear luggage case.

## Instrument and its indicating light

- 1.Left turning indicator
- 2.High beam indicator light
- 3.Indicating light for sensor key
- 4.Voltage malfunction alarm light
- 5.Photoelectric sensor
- 6.Total mileage/ Mileage subtotal
- 7.Fuel display and alarm light for low fuel level
- 8.Navigation direction
- 9.Navigation distance
- 10.Gas station reminder
- 11.Toll station reminder
- 12.Tunnel reminder
- 13.Battery voltage/100km fuel consumption reminder
- 14.Water temperature meter and alarm light for high temperature
- 15.ABS malfunction alarm light
- 16.TCS switch indicator
- 17.System malfunction indicator light
- 18.Alarm light for engine malfunction
- 19.Right turning indicator
- 20.Clock display
- 21.Call reminder
- 22.Message reminder

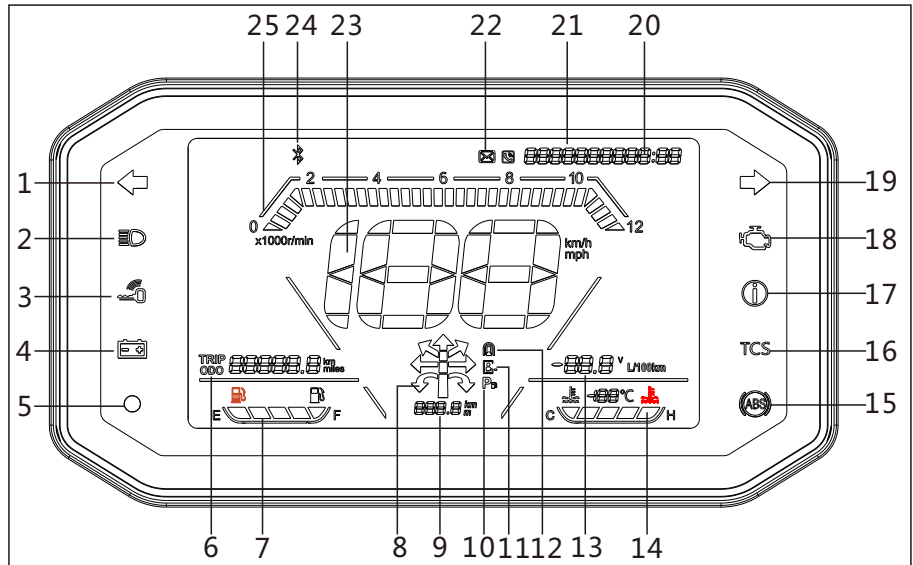

- 23.Speed display
- 24.Bluetooth connection
- 25.Display for rotation speed

Turn the ignition key to position "🔑", the instrument begins its self-inspection  
The display screen gets on and begins its self-inspection, and show you the status of motorcycle at the moment.  
Engine malfunction the alarm light "🚗" goes on, the alarm light "🛑" ABS flashing.

### **Warning**

Direct wash on instrument by high pressure water is not allowed. Wipe up the instrument by gasoline, ethanol or organic solvent is not allowed, or the instrument may partly crack or color fading.

### **Left turning light" ← "**

When push the left switch to" ← " · the indicator" ← "is on.

### **Engine malfunction alarm" 🚗 "**

When the managing system of engine is in malfunction,the alarm light" 🚗 "is on. When turned ignition key to position "🔑", the indicating light" 🚗 "gets on,After the engine started, the indicating light " 🚗 "goes off immediately.

### **Warning**

After the engine started, the indicating light" 🚗"goes on ,at this moment, the motorcycle may not be normally stated, and the fuel system may not work.

In motorcycle driving, in case the indicating light" 🚗 "permanently on , please stop using, then contact the VOGÉ dealers.

## Alarm light " " for ABS malfunction

When there was malfunction in ABS system, the indicating light "  " **permanently on**.

Turn the ignition key to position "  ", the indicating light "  " **flashing**, when the motorcycle started driving, the indicating light "  " gets off immediately.

### **Danger**

After the engine started, the indicating light"  " "permanently on", at this moment, the motorcycle may not be normally stated, and the fuel system may not work.

In motorcycle driving, in case the indicating light"  " "permanently on", please stop using, then contact the VOGÉ dealers.

## TCS indicating light" "

When the meters on motorcycle is initializing, the default for TCS is on, the sign for TCS is slowly flashing, in case there is not malfunction currently, when motorcycle is during driving, the sign of TCS on meter gets off, in case the sign of TCS flashes slowly but then gets fast, which indicates the TCS starts working; Press the switch for TCS on right switch assembly and keep above 3 seconds, the sign of TCS on meter gets permanently on, which means the TCS got off; Press switch for TCS and keep above 3 seconds, the sign of TCS on meter goes off, which means the TCS is in working; In case the TCS is working while its light permanently on, which indicates the TCS is in malfunction

### **Caution**

Every time the ignition lock moves to position ON from other position (The process of power getting on), the default for TCS is ON.

## Right turning indicating light" ⇨ "

When pushed the right turning signal switch of right switch assy. to" ⇨ " · the light" ⇨ "gets on.

## High beam indicating light" ≡D "

When pushed the headlight switch on left switch assy. upwards,the indicating light " ≡D "gets on.

When pressed the overtaking light switch on left switch assy.,"the indicating light " ≡D"gets on until you release the switch.

### **Caution**

Please periodically check and confirm the normal oil level. The only way for checking the oil level is: Check the oil level on oil gauge to confirm.

## **This alarm light reminds you fuel filling-up**

Caution: The fuel is not enough may lead engine starting failure or bad power performance, under this case, continue the use may damage the fuel pump.

Completely run out the fuel in the tank is not allowed, fill up the fuel before alarm light getting yellow.

## LED+Negative display

Speed: The running speed of motorcycle. (km/h-kilometers /hour or mph-mile/hour).

Rotation speed: Rotation speed of engine (1000r/min, 1000 rounds / each minute)

Water temperature: When the temperature is  $\geq 120\text{ }^{\circ}\text{C}$ , the alarm light for coolant temperature gets on.

Fuel level: Show you the current residual fuel.

When the residual fuel in tank is  $\leq 1.6$ , the last cell gets flashing, which reminds you fill up with fuel as soon as possible.

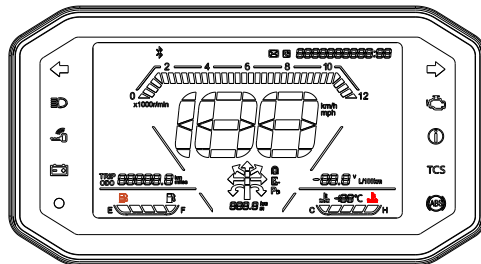

### Caution

The fuel in the tank is waving in the running, when there is a few fuel, the indicating light may be not on, which is normal, don't worry.

### Danger

Operate instrument during driving is dangerous, the hand leaves handle bar may reduce your control on motorcycle.

## Setup for clock on meter/Total or sub mileage:

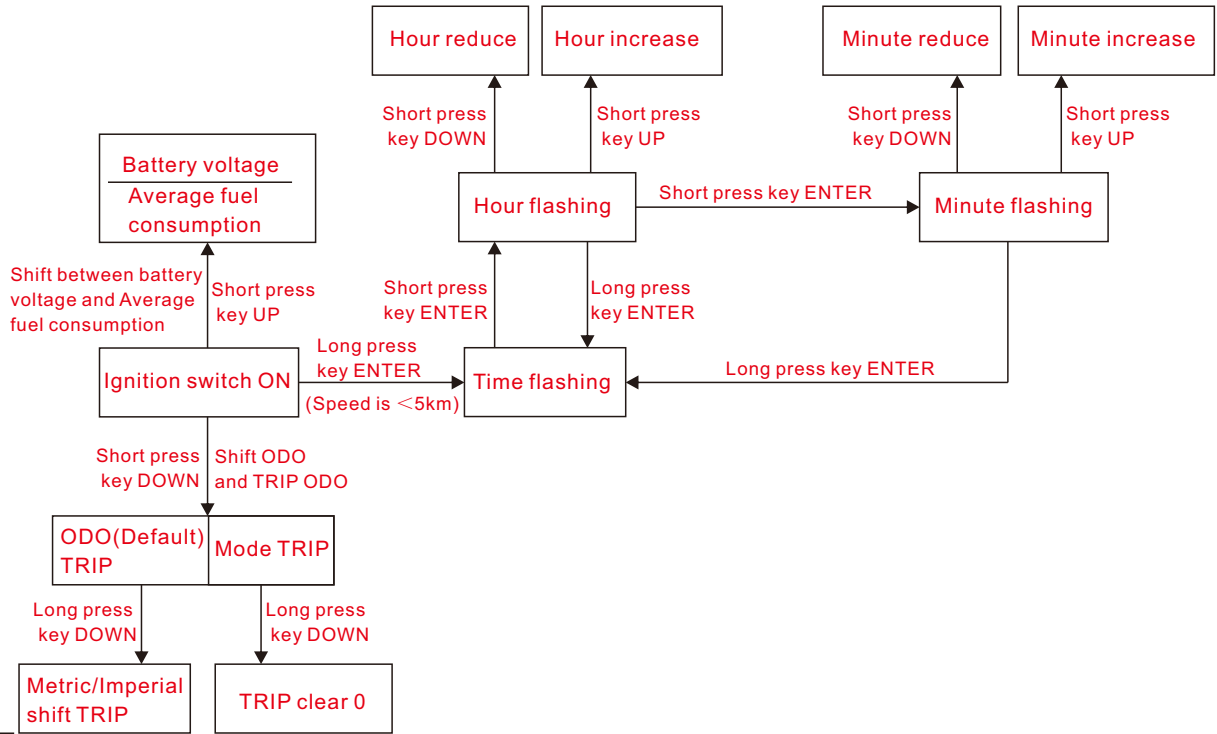



## Steering switch set

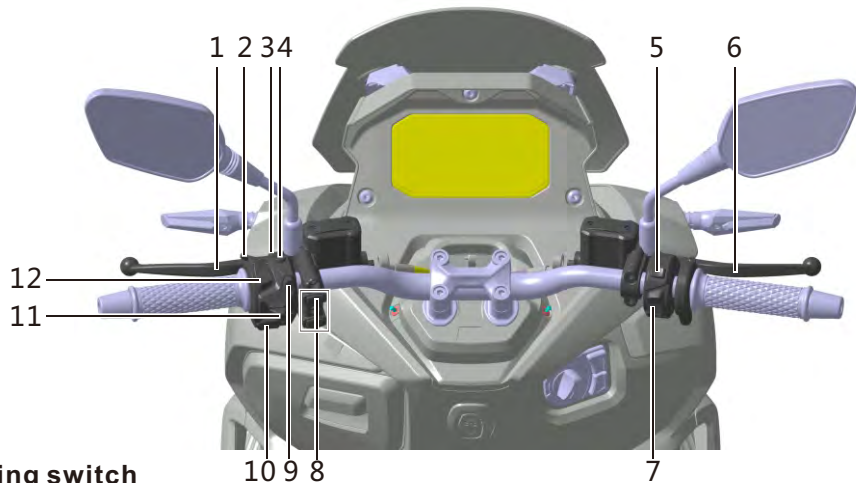

- 1.Rear brake lever
- 2.Dimmer switch/Overtaking switch
- 3.Snap shot
- 4.Confirm
- 5.TCS switch
- 6.Front brake lever
- 7.Start/Kill switch
- 8.windshield lifting switch
- 9.Emergency switch
- 10.Horn switch
- 11.Turning signal light switch
- 12.Meter Up/Down



## High/Low beam and overtaking switch

When the high beam/overtaking switch push forward to "  ",the high beam gets on,while the indicating light on instrument "  " also gets on.

When the high beam/overtaking switch move back to "  ", the low beam light gets on,while the indicating light on instrument "  "gets off.

When move back the switch"  ",the high beam is on,while the indicating light on instrument is on"  ",and it recovers when released the switch.



### Warning



The headlight could be on when the engine is stopped, the light depends on battery, so please don't long time turn on the light when the engine is stopped.

## Button " " for horn

When pressing "  ", the horn rings.

## Turning signal light switch

When push the turning signal light switch on left switch assy. to the left "  ", the turning signal light at left side both front and rear are all on, the indicating light "  " on instrument is also on.

When the switch on left switch assy. push to right "  ", the turning signal light at the right side both the front and rear are all on, its indicating light "  " is also on.

When pressed the turning signal switch on left switch assy. inward, the turning signal lights get off while its indicating light on instrument also gets off.

## Emergency light switch " "

In case the emergency light is off currently, press emergency switch on left switch assembly for locking up, then the emergency light gets on; In case the emergency light is on currently, press the emergency switch on left switch assembly for cancelling locking-up, then the emergency light gets off.

## Front brake lever

Tightly hold the brake lever, the front wheel stopped, meanwhile the rear brake light gets on.

** Danger**

In case the motorcycle is in running, the starting and parking switch is on while engine is also in the same condition, please pay attention to the throttle position.

**USB power socket "  "**

The specification of output for this model's USB power supply socket is: 5V 2A.

The water-proof cap on USB power interface is with the mark "  ", pick the cap up the USB power supplying socket could be normally used.

** Warning**

When user need this function, please prepare a charging wire by himself. After used, please cover the water-proof cap in place to prevent water or dust getting in and reduce its working life.

## ABS system

1. Deceleration and braking under normal situation, release the throttle first, tightly hold the handle bar and then brake.
2. Decelerate before turning, when passing the turning, do everything possible to keep an even speed, in case it is needed, slightly brake, the sudden braking is forbidden.
3. Decelerate in advance in case met the wet road even water on road, take care.
4. Judge the road condition in advance to avoid sudden braking.
5. When the emergency was met, swiftly release the throttle and tightly hold the handle bar and brake by full power.

### **Caution**

The model with ABS, when fully braking, the bounce with some frequency on brake lever is obvious, this is normal, don't worry, please tightly hold the handle bar.

### **Danger**

In case decelerate from high speed, use the front or rear brake only is dangerous, the motorcycle is easy to skid or get out of control, please use the front and rear brake in a balancing way.

## Driving recorder(Optional)

### Operation for the APP

#### Preparation before use

- 1.Power on and off: The motorcycle ignition machine will automatically turn on, and when the motorcycle is turned off, the machine will automatically shut down.
2. Insert memory card:Push the TF memory card straight into the card slot.
- 3.Remove the card: Push the TF card forward, and the card can be removed after it pops up.

#### ⚠ Caution

Removing the TF card in the recording state may damage the files, please turn off the card before pulling out the card.

### The WIFI function

Download "Road Cam" and "BSKJ" apps in APP Market for Android phones;

If you want to download the "Road Cam" and "BSKJ" APP from APP Store, you can scan the following QR code to download.:



### Take Road Cam APP as an example

- 1.On the mobile phone, select a WIFI signal whose name starts with wifi\_camrea. The initial password is 12345678. Go back and find the "Road Cam" APP to open the app.

#### ⚠ Caution

- 1.When the Android phone prompts that the WLAN network is unavailable, do you want to switch to the network? Select Cancel. Location permissions should be turned on.As shown in Figure 1.
2. Parking monitoring. Prolonged parking and use can lead to vehicle power consumption and battery loss, as shown in Figure 2.

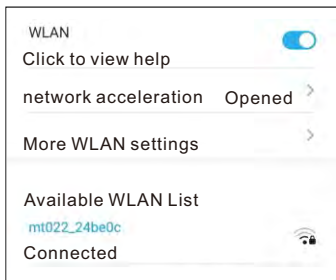

Figure1

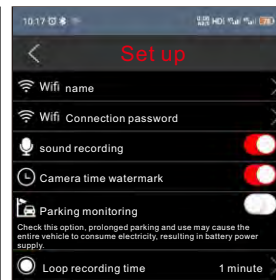
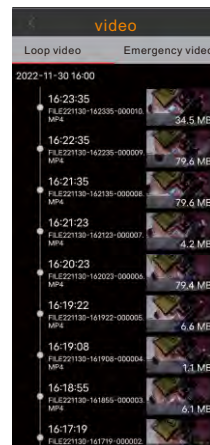
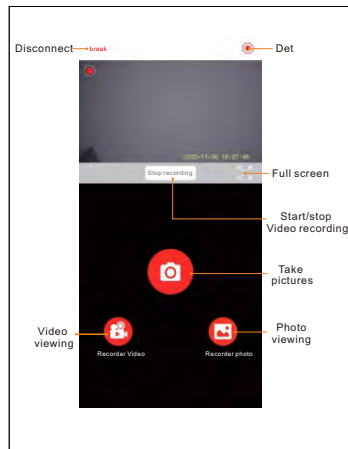
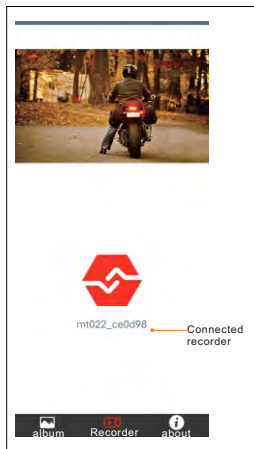



Figure2

## 2. Click icon " " Enter the main interface of the app



## 3. Ordinary video and emergency video viewing.

In the stop recording state, click "Device Video" to display a normal video; Press and hold to slide up is a normal video, slide to the left is an emergency video.

When the icon is switched to another video, view another video file "  ".

File download: Long press the file you want to download in the file browsing interface, and then click download after the download interface pops up. The downloaded file is saved in the downloads folder under the roadcam path.

## TCS traction control system

Confirm the skidding differential according to speed differential, then compare the speed between the front and rear wheel, finally fix the stability margin of rear wheel. In case more than the stability margin, the control system may adjust the engine torque.

### **Caution**

The operations of TCS under some special road conditions:

In case the front wheel gets off the ground under very high speed, the TCS may decrease the engine torque until the front wheel touched ground once again. Under this case, we suggest slightly return the throttle grip to get into stable driving once again as soon as possible.

Sudden acceleration under full throttle on smooth ground is not allowed, because the engine torque may lead to rear wheel skidding and make it unstable, which could not be controlled by TSC.

On the very soft ground such as sand or snow, the TCS can largely decrease the driving power of rear wheel even makes it stop, under this case, we suggest stop the TCS at the moment.

Except the road conditions above, for the safe driving, please always open the TCS.

The ON/OFF shift of TCS please refer to P18.

## Main stand system

This model is designed with side and main stand.

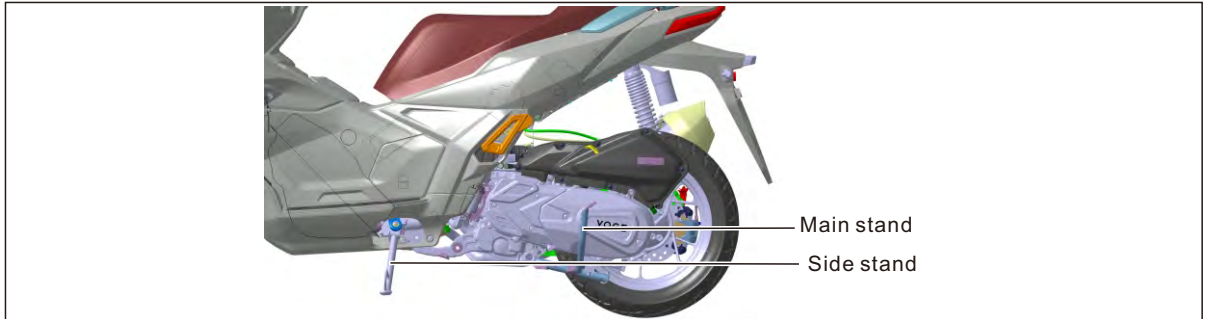

### Warning

1. Please park the motorcycle on solid and flat ground, otherwise the parking is not stable.
- 2 In case the motorcycle need be parked on slope, make its head forward to uphill to avoid turnover due to turning of side stand.
3. The design of side stand takes more consideration for the weight of motorcycle itself, so don't take your body on motorcycle when adopting the side stand to avoid distortion due to overweight.

## Engine starting

The side stand is picked up.

Check if the remote key is in the range of 1.2m to antenna.

Turn the ignition switch to position "  " .

When all the conditions above achieved, the left or right

hand need to hold brake lever tightly to keep safety, the right hand can press the electrical starting button "  " without turning throttle grip.

Start the engine to let engine keep idling until fully pre-heated.

This model is designed with prevention for wrong ignition, the engine could be started under conditions below only:

-The ignition switch is at the position ON of "  ", pick up the side stand and tightly hold the brake lever to keep safety.

### **Danger**

The emission gas of motorcycle includes CO, which is a gas without color, smell but poisonous.

Idly run the engine in room without ventilation or poor ventilation is not allowed to avoid get poisoned.

### **Warning**

Enough pre-heating makes better lubrication, to decrease engine abrasion, the colder the weather the more pre-heating minutes are needed. Long time idling working of engine is not allowed, because the poor heat radiation lead to engine overheated and damage the inner parts.

Under cold conditions, suitably turn the throttle grip while pressing the starting button to easier start.

The lubrication works only when the engine is running, so don't push the motorcycle forward for a long way when the engine is stopping. After the engine started, check the flashing or abnormal power on of indicating lights on instrument, in case it is, please top the engine and make corresponding inspection.

## Fuel filling-up

Turn the ignition switch to the position as picture shows, press the key FUEL, the decorative cover of fuel tank may automatically open, turn the fuel tank cap **anticlockwise** and then lift it up.

When the fuel filling-up finished, put the fuel tank cap back to its filling port, turn it **clockwise** to lock it down, and finally close the decorative cover of fuel tank.

Please adopt unleaded or less lead gasoline above 92#.

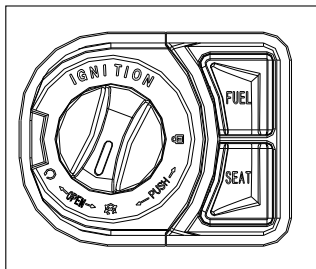

Ignition switch



Fuel tank cap

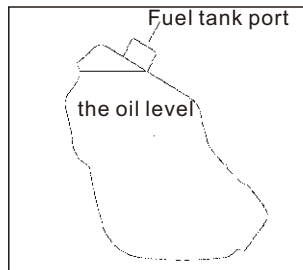

Fuel tank capacity: 9L

### **Warning**

The fuel is corrosive to painting surface, get its color fading and ugly. In case there is fuel on the painting surface, please wipe it up.

The fuel may expand when it is hot, fully fill up may lead to overflow due to too strong the internal pressure makes fuel tank distort.

When filling up the fuel, don't make it too full, let the fuel reach the bottom of anti-surge ring on fuel tank's port is enough.

### **Danger**

Please stop the engine when filling up the fuel and get it far away from spark, smoke, fire or heat source.

## VI. Malfunctions

### Too hot the coolant



This alarm light on means too high the coolant temperature.

When the engine overheated, continue the driving may damage the engine, so please follow the instructions below. Stop driving and engine until the indicating light off. Check coolant and heat radiator when the motorcycle completely cool down.

- Check coolant level: In case too low the coolant level, fill it up.
- When the coolant temperature light got on, which means the fan of heat radiator is without working, please contact the service station for troubleshooting, it is better the station authorized by us.

### Insufficient coolant

We suggest the operation below when the coolant is not enough or the heat radiator blocked by mud or sand:

- Reduce the loading to decrease the engine heat.
- Keep the engine idly run when in the traffic, don't turn the throttle to avoid engine temperature rise.
- In case the operation above fail to cool down, please stop the engine and contact the service station for troubleshooting.



This alarm light on means there is malfunction in engine. Under this case, keep driving may lead to engine ignition failure or fuel supply stopped.

Please stop the engine, turn off the ignition switch, then start once again, in case the alarm light goes off, please keep driving, in case still on, please contact the service station nearby.

## **Engine starting failure**

The side stand is laid down.

Didn't hold brake device tightly.

If the fuel is enough.

If the power in battery is enough.

## **Difficult engine starting**

–If it is in cold temperature, in case it is, slightly turn the throttle when starting.

–Battery power loss.

–Too thick the oil; Confirm if the oil need be replaced.

## **Weak engine power output**

–Check if the element of air filter is clean.

–If the motorcycle is at high altitude.

•Incorrect check and adjustment may damage your motorcycle and let you fail to find out the malfunction, which can't get the service of Quality Guarantee. In case you don't know much about the correct operation, please contact the VOGÉ dealer.

## **Malfunction's inspection and maintenance**

The content for malfunction inspection and repair in this book can only help you on normal problems, of course they are just basic ones, in case the troubleshooting failed, please contact VOGÉ dealer.

## **VII.Grinding-in**

### **Grinding-in for new motorcycle**

The grinding -in period is important to working life and fuel consumption, so before driving, read the User Manual carefully. (The correct driving within the first 1000km is good for motorcycle performance and bring you fun of driving.

### **Grinding-in for engine**

- No matter the engine is hot or cold, before starting, idly start the engine for enough time, to let oil spread to all positions need lubrication.
- During this time, the speed in the first 500km should not be over 50km/h, the second 500km without over 70km/h.
- During this time, in case the engine works under fixed low speed with light loading, this may lead to bad matching for parts and greater wear-out, so please don't drive under even speed with light loading for long time.
- During this period, the rotation of engine need be changed frequently, don't let it work under a fixed speed for a long time.

## Grinding-in for tire

- The surface of new tire is smooth, so it is dangerous to driving too fast or at turning. To get the strongest gripping force, the grinding-in is important.
- In the first 200km, you can drive at turning in low speed until all angles of tire tread completely grinded-in.
- The protrusion on tire tread is dangerous, the grinding is a good way for avoid protrusion on tire tread.

## Grinding-in for brake system

In the initial 500km, the new brake plate hasn't reached the best friction, to make up for braking loss, you can more powerfully draw the brake lever

### **Danger**

To get the best tire grinding-in, in its first 200km, sudden acceleration, turning or braking are not allowed.

## VIII.Adjsutment

### Adjustment for back-view mirror

Adjust the back-view mirror to correct position according to your own stature and driving posture.

The mirror body 1 and case 2 could adjust by hand directly.

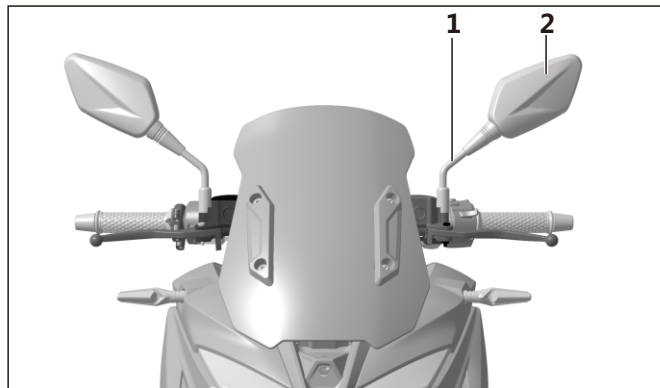

#### **Warning**

Sit on the motorcycle and keep it upright, make sure you can clearly see the object in range behind the tail of motorcycle by 10m with width 4m.

#### **Danger**

Adjust the back-view mirror during driving may reduce your control on motorcycle, so please don't do this work during driving.

## Adjustment for throttle grip

- The throttle lever is for controlling engine rotation
- Turn to your own direction is acceleration, the opposite direction is deceleration.
- The adjustment for clearance of throttle cable
  - Remove the rubber jacket 1.
  - Loosen the locking nut 2.
  - Turn the adjustor 3 to let the clearance of throttle cable to suitable distance.
  - Lock up the nut 2
  - Re-assemble the rubber jacket 1

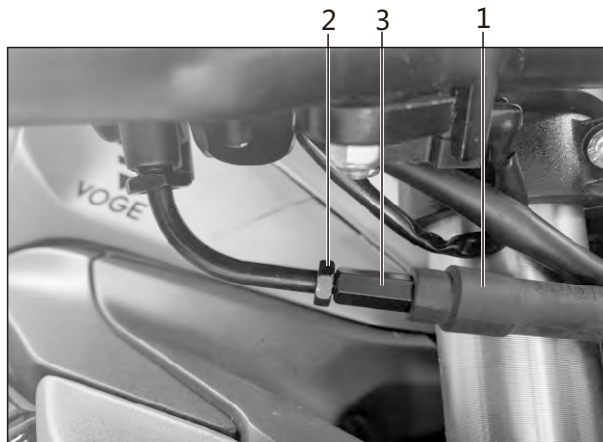

### **Caution**

After the clearance of throttle cable adjusted, make sure the throttle lever could return automatically whose idling speed should not rise.

After the clearance of throttle cable adjusted, turn the handle bar to the left and right limit, whose idling speed should not rise.

## Adjustment for headlight dimmer

- All the height of headlight must be correct under any loading of shock absorber.
- To keep safe night driving, adjust the light angle of headlight to suit different loadings.
- The adjusting screw is at the lower rear of headlight, please align the adjusting screw of figure by cross screwdriver.
- The low beam shall be turned clockwise, the light gets low, opposite is high.
- The high beam shall be turned clockwise, the light gets high, opposite is low.

### **Danger**

In case you don't know much about the height of light, please contact the VOGÉ dealer.

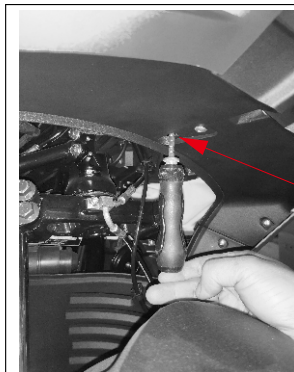
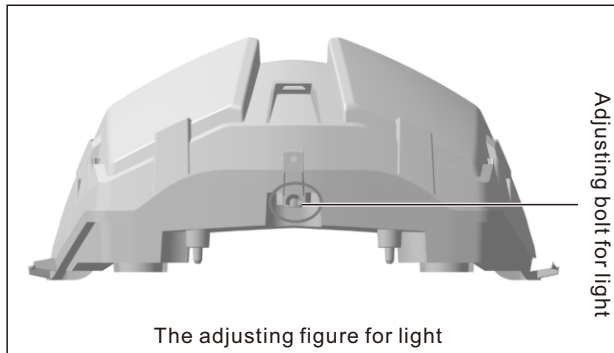

Insert the cross screwdriver along the arrow, clamp the gear combination surface and then start turning.

# IX. Inspection, repair and maintenance

## Fuel

The fuel parameter when you purchasing the motorcycle is the most fuel saving way or under a fixed speed, which is quite different to your actual driving, which may be higher than the fuel parameter for reference only.

cThe operations below may decrease the fuel consumption under correct driving:

- The driving shall be gentle, stable and without sudden braking as possible, the re-start and acceleration may use more fuel.
- Driving in the city is bad for fuel consumption, the frequent stop and move means frequent start of engine.
- Avoid driving for short distance. The fuel consumption in the first km after started is double times to normal situation due to the motorcycle hasn't reached the best working temperature.
- In case the air pressure in tire is not enough may increase the rolling resistance of wheel, and then increase the fuel consumption.
- Strictly follow the Period Maintenance table is important to save fuel.

Except the causes above, you may become more skillful with the mileage rise, for more driving fun, you may usually make sudden acceleration or deceleration, at this moment, the fuel consumption uprises compare to your former stable and gentle driving, which actually because of your change of driving style.

## The fuel evaporation

When the fuel evaporation system gets failed, please contact the VOGÉ service station. Refit on fuel evaporation system is not allowed, otherwise the emission may not meet the standard. After removal and repair, check the connection of tube joint, leakage of pipeline, or block; Check the squeeze, crack or damage on rubber hose. The fuel vapor was released into carbon canister though the desorption tube, when the engine stopped, the activated carbon in the canister absorb the fuel vapor; When the engine is working, the fuel vapor in the carbon canister releases into combustion chamber through desorption tube join the combustion, which prevent the fuel vapor get into air directly to be pollution.

The absorbing tube also make the air pressure in fuel tank get balanced, when the air pressure in fuel tank was lower than air outside, supplement the air pressure through the absorbing tube on carbon canister; In this case, please make sure all the tube smooth without blocking and squeeze, make sure the correct installation of anti-toppling valve, otherwise the fuel pump may damage or fuel tank may get distortion even damage other parts.

## The fuel evaporation control system works as below:

(1) When the gasoline in fuel tank gets heated, the gas vapor get out, absorbed after get though the end TANK of carbon canister of dumping valve.

(2) When the motorcycle inclined over  $60^\circ$ , the dumping valve gets closed,

the gasoline failed to flow into carbon canister through dumping valve.

(3) The fresh air flow from end A of carbon cannister to the end PURGE to

bring the gas vapor into throttle valve, then join combustion by getting though the air inlet tube.

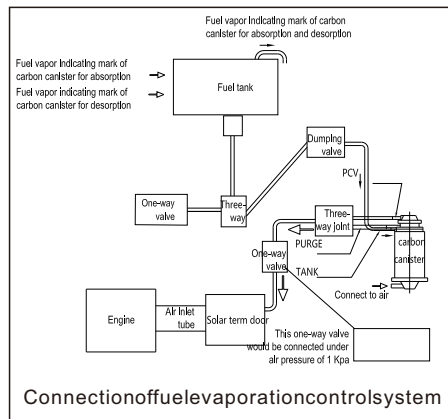

## Three-way catalyst

There is three-way catalyst in air exhausting system, which reduce the harmful agent in emission gas. The bad engine working may damage the three-way catalyst, so the actions below need be followed:

- Make period maintenance according to the stipulation in Quality Guarantee book
- When the engine works unstably, please contact VOGÉ dealer as soon as possible.
- When the fuel alarm light is on, fill up the fuel as quick as possible, too low the fuel level may lead to unstable fuel supply.
- Don't start the engine by pushing or dragging the motorcycle.
- Cut off the ignition when it is in idling only.

### **Warning**

The three-way catalyst is fragile and expensive, please adopt the gasoline without lead, in case the gasoline with lead adopted, it may damage the three-way catalyst and other important parts.

### **Danger**

Driving or parking on combustible material such as dry grass is not allowed, the working temperature of three-way catalyst is very high, it may catch fire if drive or park on combustible material.

## Tool box

The tool box is laid under the seat, open the seat, it could be seen.

After driving under bad conditions, make lubrication after washed up or driving in the rain.

## Moving parts and their maintenance

For safe driving, keep the good lubrication for moving parts is a necessary work for getting its working life longer.

- Brake lever's shaft
- Shaft for main stand
- Shaft for side stand
- Shaft for pillion step and returning spring.

## Battery

### Maintenance for battery

The battery on this model is completely free of maintenance which needn't check the electrolyte level and its ratio, but need to check the power charging periodically.

### Caution

Lubricant grease of lithium is recommended.

### Caution

In case it is possible, charge the new battery by 30 minutes for the first time, which could effectively make working life longer.

## The power charge for battery

In case the ignition lock is off, while the voltage of battery is lower than 11.5V, we suggest charge the battery.

- Charge the battery by stable DC power source or use the suitable power charger and strictly follow its instruction.
- The DC charging voltage shall be DC (14.5±0.3)V with current no more than 1A;
- The charging hours is 6 to 8, don't let the current than the maximum limit.
- The overcharging may shorten the batter working life, so don't adopt this way.
- Cut off the power circuit with motorcycle before charging.
- Usually check the cleanliness of terminal or wire joint, in case already corroded or oxidized, please clean it up.
- In case the motorcycle is usually in driving, the motorcycle may charge the battery automatically. In case just a few times or driving for short time, the power in battery may not be enough. The battery may discharge by itself, whose speed depends on the battery specification or surrounding temperature. When the surrounding temperature gets rise, the discharge speeds up, for example, the discharge speeds up by 100% with each temperature rise by 15°C
- In case the battery is without suitable charge in cold weather, the electrolyte may get frozen, then makes the battery damage or terminal distort, make the battery full of power can let it stronger in low temperature.
- Parking for a long time without driving need to cut off the negative terminal of battery first, otherwise the electrical parts on the circuit may gradually make power run out.
- Parking without driving more than 1 month need to charge the battery monthly. In case the battery is without charging for a long time may lead to natural failure.
- Correctly dispose the abandoned battery or electrolyte, don't let it be the pollution to the environment.

### Danger

The battery may produce hydrogen, so keep it far way to heat source of park.

Wipe up by dry cloth may produce spark of static electricity, to avoid this, please adopt wet one.

## Disassembly and re-assembly for battery

- Before the disassembly and re-assembly, turn off the ignition switch first.
- Remove the negative terminal first when disassembling the battery, then the positive one.
- Install the positive terminal first when re-assembling, then the negative one.
- Every time when re-assembled the battery, turn on the ignition switch for 1 minute and then turn off to let the electrical equipment initialize.

## External power supply

- When the power in battery fail to start engine, the outer power source could be adopted for engine starting.
- When the outer power source is adopted, use the wire clip for spring only of completely insulated to avoid short cut or non-jump spark between guiding wires. The battery A is the power source on motorcycle while the battery B is an outer one. The positive terminal 1 on outer power source B connect to positive terminal 2 on power source A on motorcycle, while the negative terminal 3 connect to the metallic part C on engine to connect the ground. Start the engine, in case failed, wait for minutes and then start once again to protect the engine and battery. Before removing the guiding wire of outer power source, let engine run for minutes, then cut off the negative wire and ground wire first, then the positive wire.

### Warning

Don't put the battery up side down, otherwise the electrolyte may flow out from the breathing hole.

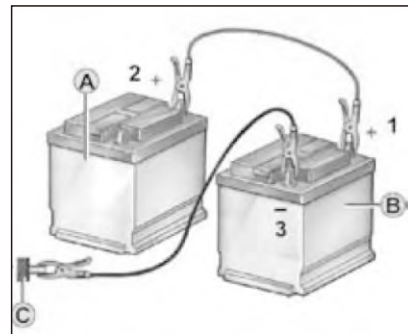

## Maintenance for air filter

- The air filter locates above engine, if it is blocked by dust, the air inlet may get harder, which reduce power output and increase fuel consumption.
- In case driving under dusty condition, clean up and replace the element more frequent.
- The cleaning up and replacement for air filter element:  
Remove the 9 pieces of screw on the case of air filter, then draw out the case of air filter.  
Remove the air inlet tube of air filter.  
Remove the element of air filter.  
·The broken element may let dust get into engine and make engine damage, so please replace the broken one.
- In case the element is installed in wrong position, the dust may bypass the element and get into engine then get engine damaged, so please install it in place.

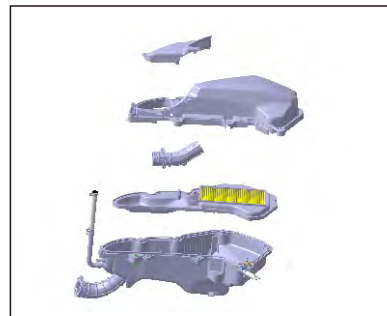

### **Caution**

When cleaning up the element, the blowing air shall inlet from the side of metallic net, in case get in from another side, the dust may stay in the clearance of element, which largely reduce the effect of cleaning up.

## Oil in engine

### engine Check the oil level

- The oil inspection window and filling up port are both at the right cover of engine.
- The checking for oil level:
  - Do this work when the engine is cold.
  - Keep the motorcycle upright.
  - Remove the oil gauge 1st and 2nd to check the oil level.
  - The correct level shall be within the upper and lower scale lines of oil view window.
- In case the oil level is higher than upper line, outlet some oil.
- In case the oil level is lower than the lower line, inlet some oil.
- No matter inlet or outlet, check the oil level once again when the operation finished.

### The maintenance for oil in engine

The oil can make sure the effective lubrication for parts in the engine, besides more, the oil helps cooling down the engine, in addition, the oil is also good for sealing the engine, so the maintenance of oil is very important.

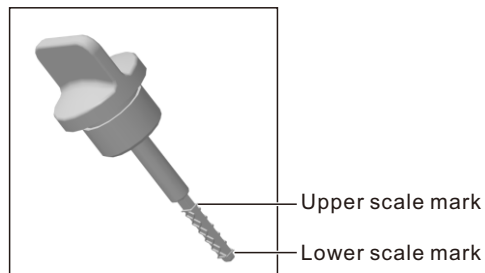
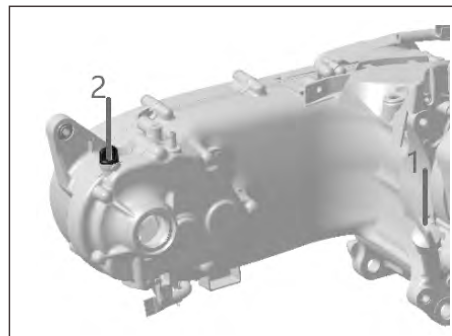

·Outlet the oil :

–In case too high the oil level, please remove the oil drainage bolt by socket wrench , the oil drainage bolts are at the middle place of engine bottom (Picture 1) and left side of tail (Picture 2).

–Outlet some oil then re-assemble the oil drainage bolt. Too high or low the oil level may both damage the engine  
Please make sure the oil is at a correct level.

Figure 1

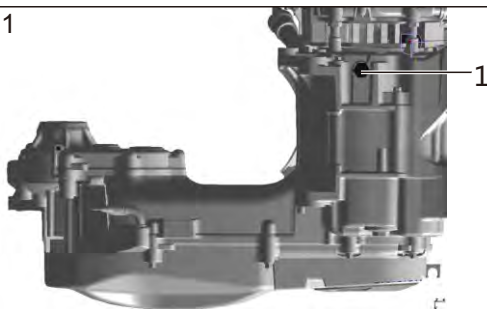
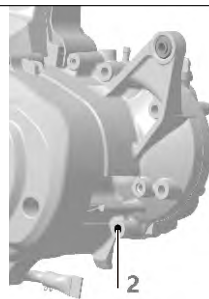

Figure 2



**⚠ Caution**

The oil may expand with temperature rise, so its level also changes. The hotter the engine the higher the oil level, while the colder engine with lower oil level, which both are normal. Keep the motorcycle upright when checking the oil level, in another word is vertical to the ground.

**⚠ Danger**

The oil drainage bolt is near the muffler, please drain the oil off when the bolt and muffler basically cooled down, when draining the oil, protect yourself from hot oil to avoid scald.

## Replacement for engine oil

- Replace the engine oil when maintenance period reached.
  - Replace the oil when engine is hot to totally drain off the old oil.
  - The replacement for oil :
    - Keep the motorcycle upright by standing rack.
    - Turn the cap of oil filling-up port anticlockwise.
    - Lay an oil tray under oil drainage bolt, then remove the bolt by tools and drain off the old oil.
- Fasten the oil drainage bolt before filling up with new oil.

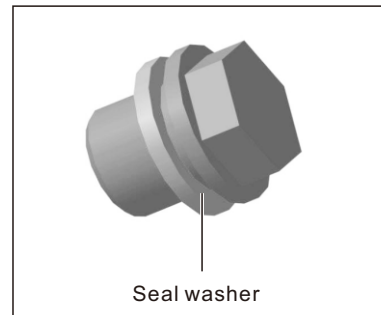

### **Warning**

Replace the oil drainage bolt and its seal ring for a new one when re-assembling, in case still use the old one, it is easy to make oil leakage.

### **Danger**

Drain off the oil when the engine is hot makes total drainage, but the hot oil and muffler may get user hurt, so before the drainage, wait for the bolt and muffler basically cooled down.



## Replacement for oil strainer

When each Maintenance period was reached, please replace the oil strainer for engine.

Replace the oil strainer when the oil in engine was drained off.

Support the motorcycle by side stand.

Remove the screw plug on the bottom of crankcase and drain off the oil in engine.

Lay a piece of oil absorption paper or a cotton cloth under the valve cover of engine, to avoid the overflow oil gets engine surface dirty when the cover was removed.

Remove the valve cover on the left side of engine.

Remove the oil strainer itself and drain off the oil.

Replace the for a new one.

(Note: The pressing spring is necessary, in case there is damage on o-ring, please replace it for a new one, then fasten the bolt for the cover with fastening torque of (20~25)N.m, then fasten the oil drainage plug: Middle place of botton (25~30) N.m, left side of tail part (18~22) N.m

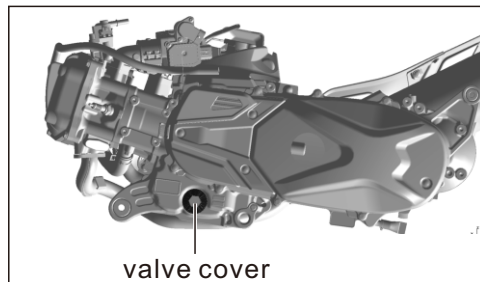

### Warning

Check the gasket on valve cover element, replace for a new one if it is necessary. A wrong oil strainer may damage the engine, please surely adopt the origin VOGÉ parts.

# Coolant

## Check and maintenance for coolant

The coolant can radiate the heat for hot parts in engine and keep its normal working temperature.

- The check and filling-up of coolant are all done in sub tank.
- Stop the engine
- Check when the engine is cold, because the coolant may expand when it got hot.
- Keep the motorcycle upright.
- Check the coolant level through expansion tank, whose level shall be between the scale line LOWER and UPPER.
- In case the coolant level is under scale mark LOWER, fill up from the port of expansion tank.
- In case the coolant level is higher than scale mark UPPER, the coolant may overflow from tube when it got hot and expand in working, for avoid hurting by hot coolant, fill up too much is not allowed.
- In case the motorcycle need fill up the coolant frequently, which means there is malfunction in the cooling system, under this case, please contact the VOGEL dealer.

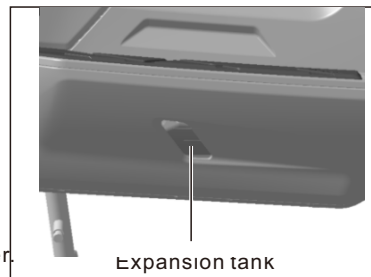
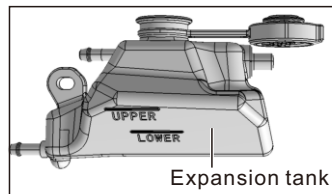

### Warning

When the expansion tank is totally dried up, don't fill up coolant by yourself, because under this case, the air may already get into the cooling system and need to be exhausted, so please contact the VOGEL dealer for maintenance.

## The replacement for coolant

· The coolant drainage:

- Keep the motorcycle upright by standing rack.
- Lay a liquid tray under the engine.
- Remove the water drainage bolt, because all the heat radiation system is connected, so all the coolant may flow out from this port.
- After the old coolant drained off, install and fasten the water drainage bolt in place.

· The coolant filling-up:

- The coolant need be filled up from the heat radiator and expansion tank the two positions:
- Open the tank cap of heat radiator and fill up with the coolant
- Check the full filling-up of coolant from the tank cap of heat radiator, pinch the water tube until it is full, then well cover the tank cap.
- After the tank's cap of heat radiator covered, start and run the engine for 30 seconds to make the coolant fully reach every position need it.
- Make the engine stop, after the engine cooled down, open once again the tank's cap of heat radiator, check if the coolant already was full, in case the level fell down, please fill up once again until it is full, then well cover the tank's cover of heat radiator, repeat this action until it gets full, in case it is necessary, it may need to repeat two times or more.
- Remove the black rubber cap of expansion tank, then fill up with coolant to the level between scale mark UPPER and LOWER.

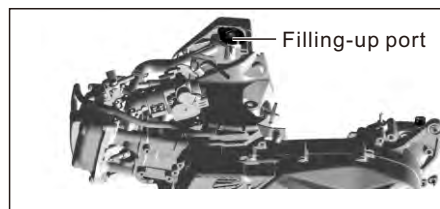
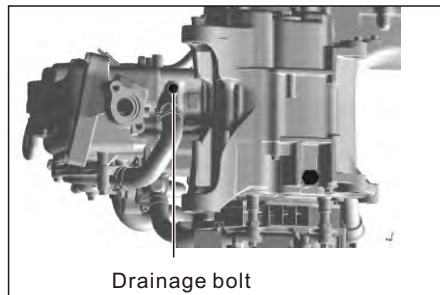

### Warning

Fill up with running water is not allowed, otherwise it may damage the cooling system, the mixture among coolant of different brand of specification is not allowed.

- In case the air temperature is lower than the one marked up on the label, please adopt the coolant fits for lower temperature.
- The VOGÉ coolant is with ice point of  $-40^{\circ}\text{C}$  with ethylene glycol but without silicate, so we suggest purchase or replace by Made in VOGÉ.

### Caution

To keep the coolant performance, replace each two years.  
 Coolant specification: VOGÉ coolant is with ice point of  $-40^{\circ}\text{C}$  with ethylene glycol but without silicate.  
 The filling-up volume: 460ml.  
 Dispose the replaced old coolant in environment friendly way.

### Danger

When filling up the coolant, in case open the tank's cap of heat radiator after engine started, please let the engine cool down first, otherwise the hot coolant may inject out and make you hurt when you opening the cap of heat radiator.

The SR1ADV engine adopts the mechanical water sealing which usually on auto or motorcycle as picture 1 shows, who are made up by dynamic ring, static ring, spring and seal ring with overflow hole as picture 2 shows, the static ring tightly stick to dynamic ring under the force of spring, which produce pressure on surface for a long term and then the reliable moving seal occurs, when the water pump is working, the dynamic and static ring are relatively sliding, which could not be completely sealed, so there may a little leakage of water drop gets out from overflow hole, this situation is normal, which is not harmful to normal driving and not any damage on motorcycle.

Picture 1

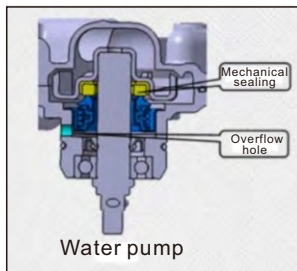

Pictur2

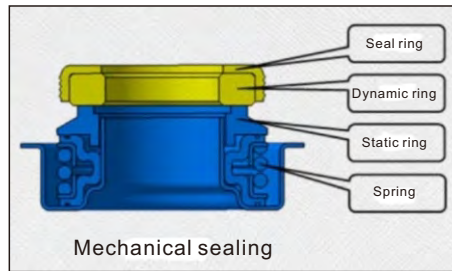

## Brake liquid

The brake liquid is an important part in hydraulic system for power transmission, so it need be reliable under high, low temperature or flowing performance at low temperature and good in anti-corrosive, so please adopt the correct one.

### Check the brake liquid

- Too low the liquid level in brake oil cup may let air get into brake system to reduce the braking performance. So please periodically check the liquid level.
- Check and fill up the brake liquid shall conduct at the front and rear oil cup.
- The liquid level shall not be higher than mark (UPPER or MAX), when it lower than mark (LOWER or MIN), please fill up immediately.
- The brake liquid is corrosive, which is bad for the surface of plastic or paint.

#### Warning

In case the filling-up of brake liquid is needed, open the cap of oil cup by yourself may let air and moisture in, which largely reduce the braking performance even failure, so please contact VOGÉ dealer to do this work.



### The specification of brake liquid

- When there is impurity or moisture in the brake liquid, please filter or replace, otherwise it may reduce the pressure for braking and make bad braking performance, especially in wet weather or place.
- The brake liquid works more than 2 years, it may get bad due to the long work, please replace immediately.

The specification for brake liquid is: DOT3 or DOT4, Please dispose the replaced old liquid in environment friendly way.

#### Caution

Mixture of brake liquid among different brand and specification is not allowed due to the different formula of different brake liquid may let the braking performance fall down.

## Tire

The tire connects the motorcycle and ground, it is very important, the incorrect specification and status is very bad for motorcycle performance.

### The tire pressure in tire

- The wrong tire pressure makes its working life shorter.
- Too low the tire pressure makes difficult turning, and speed up the tire wear-out.
- Too high the tire pressure decreases the contact area between tire and ground, which is easy to skid and out of control.

When driving in high speed, the centrifugal force may open the air valve core on the tire, to avoid the sudden air leakage, we equip it a rubber with metallic liner, cap and connect with air valve core by thread.

- The pressure of tire's air charging rises with tire temperature, so adjust the tire charging pressure when it is cold and its temperature almost the same with surroundings.

### Check the limit of tire wear-out

- The tire surface is with the mark of wear-out.
- In case the tire tread already reached the mark, which means the tire could not be used any more.
- The wear-out mark is near the TWI mark at tire edge, the wear-out mark is in the water drainage groove on tire tread, which is a protrusion, when the protrusion is worn out, means the tire already worn out and need to be replaced.
- The worn out tire may get penetrated and bring motorcycle out of control.
- When the depth of tire tread reached the minimum limit, its performance and gripping force may largely fall down.

### Danger

The incorrect tire pressure is not only bad for performance, but also lead to accident.  
Overloading may lead to tire failure and bring motorcycle out of control.  
Make monthly inspection on tire pressure.

Under normal temperature, please check the tire pressure as table below.

|            | Pressure in tire |
|------------|------------------|
| Front tire | 225KPa           |
| Rear tire  | 225KPa           |



## **The repair for tire**

Repair the small hole on tubeless tire, please remove the tire first, patch up inside of tire without outside, because the high speed driving may lead the outside patch outside flexible under centrifugal force.

- Within 24 hours after patched up, the max speed shall not be higher than 80km/h.
- In case the side of tire get broken while the breaking size is bigger than 6mm, the tire could not be used any more.
- In case many damages such as damage, scratch or wear-out were found on the tire, the tire need be replaced.

## **The replacement for tire**

- When replacing the tire, two tires on one motorcycle with different brand, specification, tire tread or 1 new while another is old are all not allowed.
- After the tire replaced, the motorcycle needs to make dynamic balance and alignment, in case the dynamic balance is poor, the operation performance of motorcycle may fall down, also makes uneven wear-out on tire.
- The rolling direction of tire has the mark arrow, turn the tire along this direction only, which make sure water & skidding proof, improve gripping force, reduce noise and make working life longer, get the tire performance better.
- The tires with given specification are all strictly tested, who meet the demands of most road conditions, while the ones without test can't make sure the safety and suitability.
- Seal the contact position between the wheel rim and tire lip of tubeless tire.
- To avoid air leakage, the tubeless tire needs special tool and machine for disassembly and re-assembly, while pay attention to protect the tire pressure sensor.
- The tire replacement need be done by VOGÉ dealer, they are skillful and with necessary tools or machine.

## Fuse chip

Before replacing the fuse chip, please know well about the root cause first and make troubleshooting.

This model adopts fuse box (1 pcs).

We marked up the specification and how to use for each fuse chip.

-Fuse chip for power supply to motor of ABS1 system (15A): Control power supply to motor of ABS system. Spare chip: 15A (In the fuse box).

-Fuse chip for power supply to solenoid valve of ABS2 system (10A): Control power supply to solenoid valve of ABS system. Spare chip: 10A (In the fuse box).

-Fuse chip for power supply to non-EFI system IGN (15A): Control the instrument, lights, horn, starting relay, and switch assemblies. Spare chip 15A (In the fuse box).

-Fuse chip for power supply to EFI system ECU (15A): Fuse for main power supply of EFI and oil pump. Spare chip: 15A (In the fuse box).

-Fuse chip for main power supply of EFI and main relay (15A): Control power supply for ECU of EFI system, oxygen sensor, ECU interface for diagnosis, oil injector, ignition coil and other parts of EFI. Spare chip: 15A (In the fuse box).

-Fuse chip for power supply of fuel pump and pump relay (10A): Control the power supply for fuel pump. Spare chip: 10A (In the fuse box).

Fuse box

|                        |  |
|------------------------|--|
| Spare fuse chip<br>30A | Main<br>30A  |
| Spare fuse chip<br>15A | IGN<br>15A<br>ABS1<br>15A<br>ABS2<br>10A<br>BCM<br>10A |
| Spare fuse chip<br>25A | Charge<br>25A<br>ECU<br>15A                            |
| Spare fuse chip<br>10A | Main Relay<br>15A<br>Pump Relay<br>10A                 |

- Fuse chip for main power supply (30A): Control the power supply to all motorcycle system except Charging supply for EFI system and BCM. Spare chip: 30A (In the fuse box).
- Fuse chip for BCM (10A): Control power supply to left and right turning signal light, braking light, and ignition switch. Spare chip 10A (In the fuse box).
- Fuse chip for charging power supply (25A): 2 in 1 controller and charging circuit fuse chip. Spare chip : 25A (In the fuse box).
- When the fuse chip was checked or replaced, please well cover the cap of fuse box to avoid water getting in in rainy day or after motorcycle washed, which is easy to lead to electrical malfunctions.

 **Caution**

In case the fuse chip usually burns out in short time, which indicates there is malfunction in electrical system, please contact the VOGÉ dealer immediately.

 **Danger**

Please use the fuse chip with given specification, substitution such as aluminum sheet or iron wire are not allowed.

Connect the fuse chip out of our suggestion is not allowed, otherwise it is very bad for circuit even catch fire or burn out the motorcycle.

## The brake pads

The abrasion of brake pad passed the min. thickness limit may lead to poor braking performance, under some cases, it may lead to brake system damage. For the reliability for braking, the abrasion passed Min. thickness limit is not allowed.

### Replacement for brake pad

The correct replacement needs to remove the wheels, so this work shall be done by VOGÉ dealer.

No matter the front or rear brake pads, replace them in pairs as a set, in case only replace one piece of them, it may make imbalance brake even accident. After the brake pads removed, don't operate the brake lever, otherwise the brake piston may return hardly, meanwhile making leakage of brake liquid.

The oil or other dirt touches brake pad and plate when replacing is not allowed, in case if there is, please clean it up, otherwise it may make poor braking performance.

Limit for front pad:

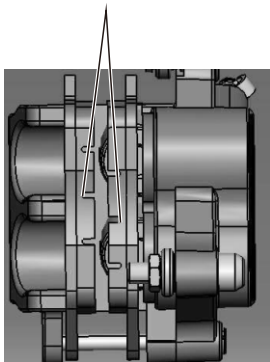

Limit for rear pad:

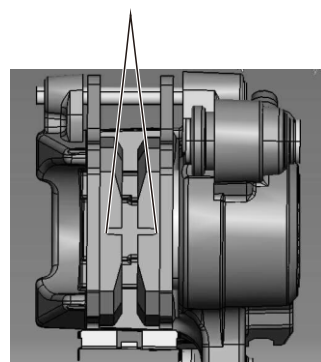

### Danger

When replaced for new pads, please repeatedly confirm the brake lever, confirm the pads tightly press the brake plate, meanwhile confirm the free travel of brake lever.

## Replacement for secondary fuel filter

The secondary fuel filter is for filtering the impurity in fuel and stop it getting into fuel injector. The nozzle for fuel injector is a fine work, easy to be blocked by impurities, in case it is, the blocked fuel injector can not work and makes engine starting failure. Please replace the secondary fuel filter on time.

-When removing the secondary fuel filter, absorb the splashing fuel from tube inside by cotton cloth.

|  |
|--|
|  <b>Caution</b> |
| Replace the secondary fuel filter each 6000km.   |

Dispose the replaced secondary fuel filter in environment friendly way.

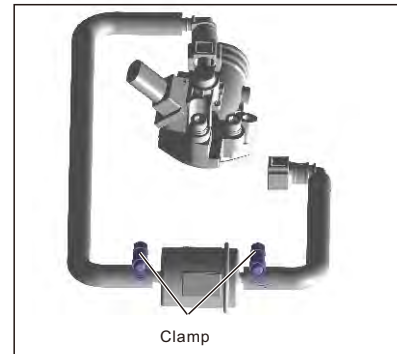

## The replacement for light signal

If there is no light signal, you may be in danger, because the light helps others easily pay attention to you and your motorcycle.

Please replace the broken lights.

The headlight, front position light, turning signal light, rear position light, brake light and registration plate light are all LED and sealed, in case broken, go to the service station for replacement. The replacement for lights please follow the description and specification below:

The dirt especially the grease on light's surface may be bad for heat radiation, which lead to light overheat even reduce its working life.

| Parameters for electrical system |                    |
|----------------------------------|--------------------|
| Battery specification            | 12V8Ah             |
| Headlight (High/Low beam)        | 12V 33W/15W        |
| Front position light             | 12V 3W             |
| Rear position light              | 12V 1.5W           |
| Rear brake light                 | 12V 4W             |
| Front turning signal light       | 12V 0.48W          |
| Rear turning signal light        | 12V 0.48W          |
| Rear registration plate light    | 12V 0.257W         |
| Specification for fuse chip      | 30A, 25A, 15A, 10A |

### Warning

When a signal light is broken, replace for a new one with completely same rating power and specification, otherwise the different one may lead to electrical circuit overload or light broken very early.

# Maintenance plan

The table below shows you the inspection for each periodic maintenance, whose interval of time and mileage, set whom reached first as standard, and make the inspection as table below every time.

|  |   | Periodic maintenance table |                       |   |    |    |    |    |    |
|--|---|----------------------------|-----------------------|---|----|----|----|----|----|
| Items  |   | Interval                   | km×1000               |   |    |    |    |    |    |
|  |   |                            | 1                     | 7 | 13 | 19 | 25 | 31 | 37 |
| Power transmission system  | Lubricating oil   |                            | R                     | R | R  | R  | R  | R  | R  |
|  | Lubricating oil filter element  |                            | R                     | R | R  | R  | R  | R  | R  |
|  | Lubrication oil level check   |                            | I                     | I | I  | I  | I  | I  | I  |
|  | Fuel line seal check  |                            | I                     | I | I  | I  | I  | I  | I  |
|  | Fuel pump filter element inspection                                   |                            | I                     | I | I  | I  | I  | I  | I  |
|  | Fuel filter   |                            | \                     | R | R  | R  | R  | R  | R  |
|  | Throttle body   |                            | \                     | C | C  | C  | C  | C  | C  |
|  | Coolant level check   |                            | I                     | I | I  | I  | I  | I  | I  |
|  | coolant   | 2 years                    | \                     | \ | \  | \  | \  | \  | R  |
|  | Air intake system seal inspection                                     |                            | I                     | I | I  | I  | I  | I  | I  |
|  | Valve clearance   |                            | I                     | I | I  | I  | I  | I  | I  |
|  | Spark plug clearance  |                            | \                     | I | I  | R  | I  | I  | R  |
|  | Air filter element  |                            | I                     | C | R  | C  | R  | C  | R  |
|  | Transmission box oil  |                            | R                     | \ | \  | \  | R  | \  | \  |
| Lubrication system   | Throttle operating system   |                            | A                     | A | A  | A  | A  | A  | R  |
|  | Clutch operating system   |                            | A                     | A | A  | A  | A  | R  | A  |
|  | Directional bearing lubrication and tightness check                   |                            | I                     | \ | L  | I  | L  | I  | L  |
|  | Check lubrication of front and rear wheels and sprocket seat bearings |                            | \                     | L | L  | L  | L  | L  | L  |
|  | Lubrication inspection of main and auxiliary pedestal rotation shaft  |                            | \                     | L | L  | L  | L  | L  | L  |
|  | Side support shaft lubrication check                                  |                            | \                     | L | L  | L  | L  | L  | L  |
|  | Brake and clutch handle shaft lubrication check                       |                            | \                     | L | L  | L  | L  | L  | L  |
|  | Rear damping shake frame bearing lubrication inspection               |                            | \                     | L | L  | L  | L  | L  | L  |
|  | Plain fork shaft bearing lubrication inspection                       |                            | \                     | L | L  | L  | L  | L  | L  |
|  | Battery voltage   |                            | \                     | I | I  | I  | I  | I  | I  |
| Others   | Seal performance for brake oil tube                                   |                            | I                     | I | I  | I  | I  | I  | I  |
|  | Brake liquid  | 2 years                    | I                     | I | I  | I  | I  | I  | I  |
|  | Brake liquid level  |                            | I                     | I | I  | I  | I  | I  | I  |
|  | Fr.&Rr. Brake pads  |                            | I                     | I | R  | I  | R  | I  | R  |
|  | Fr.&Rr. Brake switch  |                            | I                     | I | I  | I  | I  | I  | I  |
|  | Check fuel evaporation system   |                            | I                     | I | I  | I  | I  | I  | I  |
|  | Check tightness of fastening parts on body                            |                            | I                     | I | I  | I  | I  | I  | I  |
|  | Check leakage for Fr. & Rr. shock absorbers                           |                            | I                     | I | I  | I  | I  | I  | I  |
|  | Aluminium alloy wheel/Spoke wheel                                     |                            | I                     | I | I  | I  | I  | I  | I  |
|  | Rear disc brake friction vane guide rod                               |                            | Change every 12000 km |   |    |    |    |    |    |
| Engine front buffer sleeve   |   |                            |                       |   |    |    |    |    |    |
| Engine rear buffer jacket  |   |                            |                       |   |    |    |    |    |    |
| Meaning of symbols I: Inspection C:Clean R: Replacement A: Adjustment L: Lubrication |   |                            |                       |   |    |    |    |    |    |
| The first maintenance is 1000KM, and then 6000Km each.                               |   |                            |                       |   |    |    |    |    |    |

## Routine check table for key fastening parts

| Ref. No. | Fastening position                                       | Installation position                               | Thread     | Numbers | Torque (N.m)  |
|----------|--|---|------------|---------|---|
| 1        | Installation bolt for lower disc brake pump              | Front disc brake pump                               | M8 x 1.25  | 4       | 26±4  |
|          |  | Rear disc brake pump                                |            |         |   |
| 2        | Locking nut and bolt for handle bar                      | Handle bar and steering stem                        | M10 x 1.25 | 1       | 60±5  |
| 3        | Dust proof nut for steering stem                         | Steering stem and frame                             | M26 x 1    | 1       | Fasten by torque of 80N.m for front wheel, then swing left and right twice, then turn back by 1/2 round, then lock up by torque of 10N. |
| 4        | Locking nut for steering stem                            | Steering stem and frame                             | M26 x 1    | 1       | 65±5  |
| 5        | Locking bolt for front shock absorber                    | Front shock absorber and steering stem              | M10 x 1.25 | 4       | 40±5  |
| 6        | Locking nut and bolt for front wheel                     | Front wheel and front shock absorber                | M12 x 1.25 | 1       | 50±5  |
| 7        | Locking bolt for disc brake plate                        | Front brake plate and front wheel                   | M8 x 1.25  | 5       | 26±4  |
|          |  | Rear brake plate and rear wheel                     |            | 4       |   |
| 8        | Locking bolt for ring gear                               | Ring gear and front wheel                           | M5         | 3       | 4.5±0.9   |
|          |  | Ring gear and rear wheel                            |            | 4       |   |
| 9        | Locking bolt for fuel tank                               | Fuel tank and frame                                 | M8 x 1.25  | 4       | 22±3.3  |
| 10       | Locking bolt and nut for side stand                      | Side stand and frame                                | M10 x 1.25 | 1       | 40±5  |
| 11       | Shaft and nut for engine holder                          | Engine holder and frame                             | M10 x 1.25 | 1       | 50±5  |
|          |  | Engine holder and engine                            |            | 1       |   |
| 12       | Locking nut for rear shock absorber                      | Left rear shock absorber and frame                  | M12 x 1.25 | 1       | 50±5  |
|          |  | Left rear shock absorber and frame                  |            | 1       |   |
| 13       | Locking bolt for rear shock absorber                     | Left rear shock absorber and engine                 | M8 x 1.25  | 1       | 26±4  |
|          |  | Right rear shock absorber and its connecting piece  |            | 1       |   |
| 14       | Locking bolt for main footrest's bracket                 | Bracket of left main footrest and frame             | M6         | 2       | 9±1.35  |
|          |  | Bracket of right main footrest and frame            |            | 2       |   |
| 15       | Locking bolt for pillion step                            | Left pillion step set and frame                     | M8 x 1.25  | 2       | 22±3.3  |
|          |  | Right pillion step set and frame                    |            | 2       |   |
| 16       | Locking bolt and nut for windshield's bracket            | Windshield's bracket and frame                      | M8 x 1.25  | 2       | 26±4  |
| 17       | Cap-shaped nut for locking muffler                       | Muffler and engine                                  | M8 x 1.25  | 2       | 26±4  |
| 18       | Locking bolt for muffler                                 | Muffler and connecting piece of rear shock absorber | M8 x 1.25  | 3       | 26±4  |
| 19       | Locking bolt for connecting piece of rear shock absorber | Connecting piece of rear shock absorber and engine  | M10 x 1.25 | 2       | 40±5  |
| 20       | Locking nut for output shaft of rear wheel               | Output shaft of rear wheel                          | M16 x 1.25 | 1       | 120±5   |
| 21       | Locking bolt for luggage rack                            | Luggage rack and frame                              | M8 x 1.25  | 4       | 22±3.3  |
| 22       | Locking bolt for air filter                              | Air filter and engine                               | M6         | 2       | 9±1.35  |
| 23       | Locking bolt for upper brake pump                        | Front upper brake pump and handle bar               | M6         | 4       | 9±1.35  |
|          |  | Rear upper brake pump and handle bar                |            |         |   |
| 24       | Locking bolt for ABS oil tube                            | ABS oil tube and ABS controller                     | M10 x 1.0  | 4       | 24±3  |
| 25       | Locking bolt for ABS oil tube                            | ABS oil tube and front brake pump                   | M10 x 1.25 | 4       | 35±5.25   |
|          |  | ABS oil tube and rear brake pump                    |            |         |   |
| 26       | Connecting piece for high pressure oil tube              | Oil tube of high pressure and fast change joint     | Clamp set  | 4       | 4.5±0.5   |
|          |  | Oil tube of high pressure and fuel filter           |            |         |   |

- Please carefully and strictly make periodic maintenance according to requirement of this book.
  - The maintenance in the table only the least user needs to do. In case your motorcycle is usually driving under bad conditions, the maintenance shall be more frequent than the table
  - After a long driving in sandy weather or muddy road, the special maintenance is necessary.
  - We suggest this kind of work shall be done by VOGÉ dealer.
  - Correctly dispose the abandoned materials such as cleanser or waste oil, don't let them to be pollutions.
- The key for correct maintenance is the spare parts, in case you fail to confirm who made the parts, this kind of parts may lead to accident.
- We suggest this kind of work shall be done by VOGÉ dealer.

## x.Maintenance for the motorcycle in long parking

### Storage for motorcycle

The storage

- In case the motorcycle needs to park for a period without driving, the special maintenance is necessary, which need some special tools, equipment or technologies, because of this, we suggest these works shall be done by VOGÉ dealers.
- If your prefer to do these works by yourself, please do as below:
  - Totally replace for new oil.
  - Block the air inlet port of air filter and exhaust port of muffler by cloth with new oil, to avoid moisture get into engine,
  - Totally drain off the fuel in the fuel tank.
  - Remove the battery, then wash its surface by neutral soap water, meanwhile cleaning up the oxidizing material on its terminals.
  - Store the battery in a room with temperature above 0°C.
  - Adjust the tire pressure to stipulated one/
  - Totally wash up the motorcycle.
  - Spray the protective agent on rubber parts' surface
  - Spread the protective wax for auto on the covering parts of this motorcycle
  - Finally well cover the motorcycle by dry cloth and park the place with fine air ventilation.

The re-use

- Totally clean up the motorcycle. Remove the cloth blocked the air inlet port of air filter and exhaust port of muffler.
- Totally replace the oil in engine and oil element. Re-install the battery. Start the motorcycle.



**Caution**

Charge the battery monthly.

## Protection for motorcycle

- According to the daily driving, usually wash the motorcycle and keep it clean and dry.
- Wash up the dirt, bird shit, asphalt or salt on motorcycle surface as quick as possible.
- Try best to cover the motorcycle by dry cloth, long time exposed under sunshine may make covering parts get aged or color fading.

## The cleaning up for motorcycle.

- Wash the motorcycle by cold water.
- Totally wash up the motorcycle by soft cloth and neutral cleanser.
- Don't wash the motorcycle by spray.
- Don't wash the motorcycle by high pressure water.
- When driving motorcycle in low temperature, high moisture, rain or after washed, there may be some moisture in the lights, turn on the light for a while the moisture may disappear, because there is design of ventilation hole, which are normal.

### **Danger**

The wet brake may have poor braking performance, so please repeatedly test the brake system after motorcycle washed, and fast dry it up.

# XI. Electrical diagram

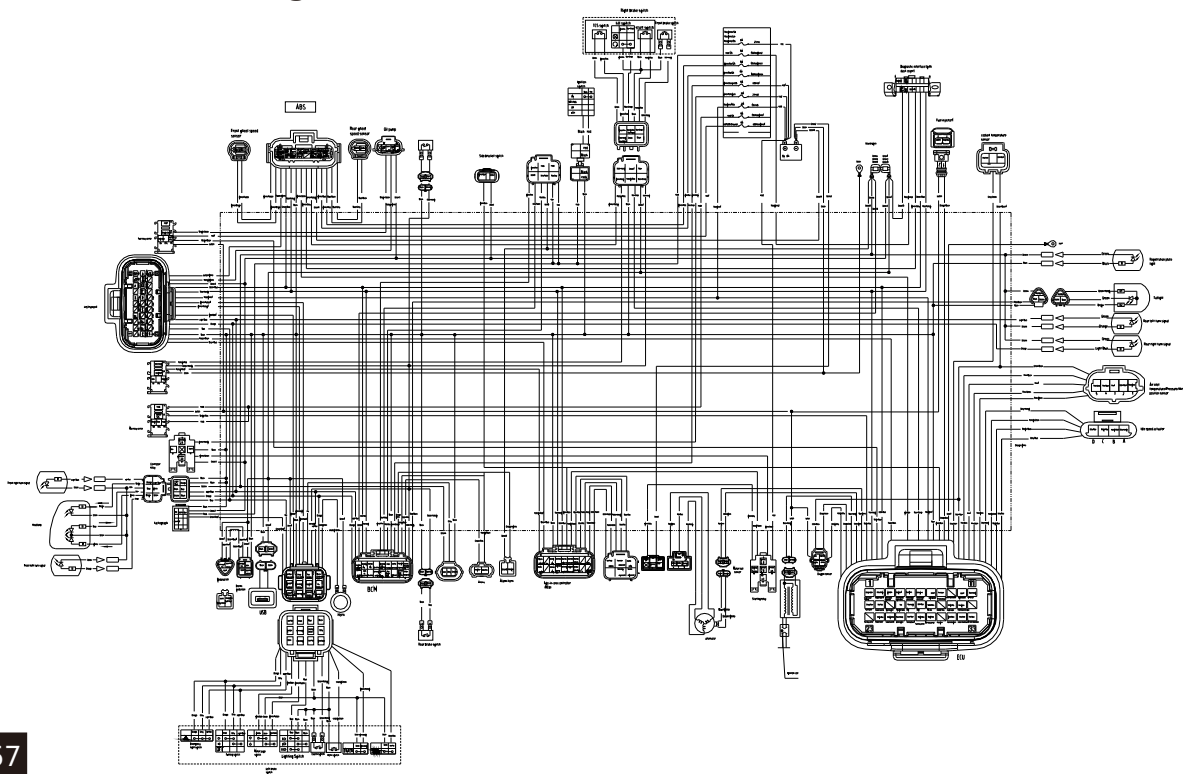



Facebook

[www.vogeglobal.com](http://www.vogeglobal.com)